

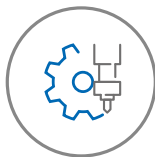

More Precision

capaNCDT // Capacitive sensors for displacement, distance & gap





Capacitive sensors for industrial applications

Capacitive sensors are designed for non-contact measurement of displacement, distance, position and thickness. Their high signal stability and excellent resolution impress in numerous industries. These versatile and robust sensors offer an optimal solution for industrial measurement tasks from machine control to process monitoring.

- Industrial-grade sensors, controllers and sensor cables
- Precise and long-term stable measurements with excellent temperature stability
- Maximum interference immunity against magnetic fields
- Extensive sensor portfolio: replaceable sensors in various designs, versions, and sizes
- Numerous interfaces for integration into machines and systems

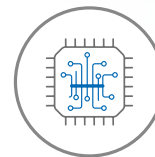











Capacitive sensors in laboratory, cleanroom and vacuum

Capacitive sensors from Micro-Epsilon are ideal for nanometer measurements in controlled environments, e.g., laboratories, cleanrooms, vacuum chambers and clean production lines. Their high performance makes them ideal for a wide range of applications in the semiconductor and electronics industries.

- Nanometer precision in clean environments
- Passive sensors for vacuum applications
- Highly particle-free sensor design (up to cleanroom class ISO1)
- Vacuum-compatible accessories
- Modern and user-friendly controller technology

Overview

Introduction		from page 4
	Measuring principle and applications	4 - 5
	Product portfolio and advantages	6 - 9
	Capacitive system design	10
	Capacitive sensors for OEM	11
	Application examples	12 - 13
Sensors		from page 14
	Cylindrical standard sensors (socket) Measuring ranges: 0.05 mm to 10 mm	16 - 19
	Cylindrical sensors in very compact design (socket) Measuring ranges: 0.1 mm to 3 mm	20 - 21
	Cylindrical sensors with thread (socket) Measuring ranges: 0.5 mm to 3 mm	22 - 23
	High-precision cylindrical sensors (integrated cable) Measuring ranges: 0.2 mm to 2 mm	24 - 25
	Flat sensors (integrated cable) Measuring ranges: 0.2 mm to 3 mm	26 - 27
	Gap sensors (integrated cable & socket) Measuring ranges: 0.5 mm to 6 mm	28 - 33
	Sensors for challenging environments: High/low temperatures, magnetic fields, vacuum and cleanroom Measuring ranges: 0.25 mm to 10 mm	34 - 38
	Dimensions of cable connectors	39
Controller		from page 40
	capaNCDT 6100 Compact industrial measuring systems (1 channel) Resolution: max. 0.35 nm Frequency response: up to 20 kHz (-3dB)	42 - 43
	capaNCDT 6200 High-performance measuring system (up to 4 channels) Resolution: max. 0.05 nm (with DL6230) Frequency response: up to 20 kHz (-3dB)	44 - 47
	capaNCDT 6500 High-performance measuring system (up to 8 channels) Resolution: max. 0.015 nm Frequency response: up to 8.5 kHz (-3dB)	48 - 49
	Controller dimensions	50 - 51
Accessories		from page 52
	Cables and connections	52 - 53
	Accessories	54 - 57
Additional information		from page 58
	Technical details	58 - 59
	Application specific systems	60 - 67

More precision – Capacitive sensors from Micro-Epsilon

capaNCDT

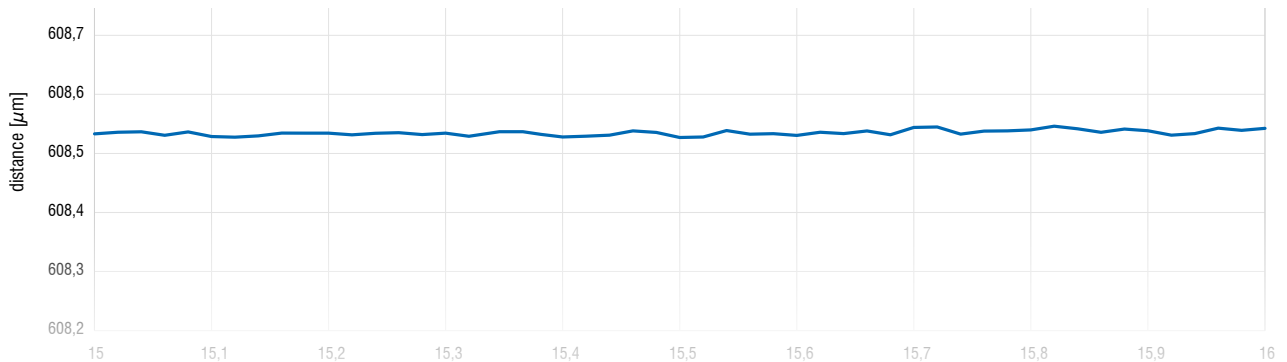

Measuring principle

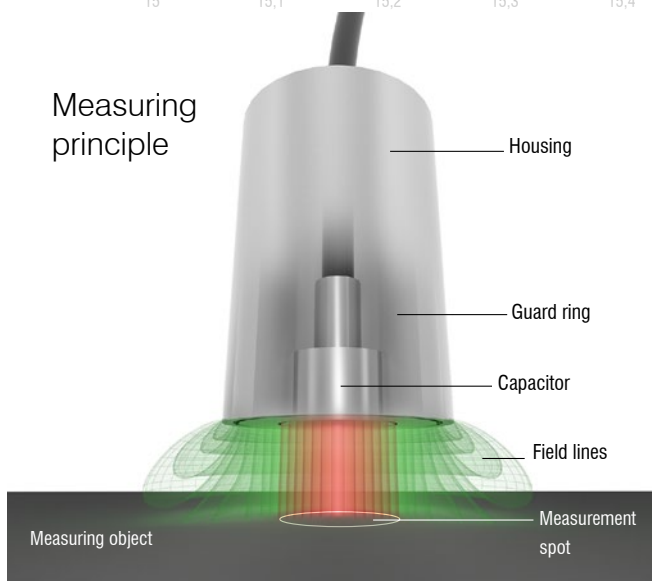

Advantages of the measuring principle

- Wear-free and non-contact measurement
- Distance and thickness measurements on conductive and non-conductive objects
- Unmatched accuracy and stability
- High frequency response for fast measurements
- Ideal for industrial environments with high and low temperatures, magnetic fields and vacuum

Low-noise technology for maximum precision

The capaNCDT sensors are based on the principle of the ideal plate capacitor. Two plate electrodes are represented by the sensor and the measuring object. If a constant alternating current flows through the sensor capacitor, the amplitude of the alternating voltage on the sensor is proportional to the distance between the capacitor electrodes. The alternating current is demodulated and output as an analog or digital signal.

Capacitive sensors from Micro-Epsilon are suitable for both clean environments and industrial measurement tasks. The low-noise technology developed by Micro-Epsilon enables measurement results with maximum resolution and outstanding stability.

Wide range of applications

Measurement of distance, thickness and gaps with highest precision

Distance measurement on electrically conductive objects

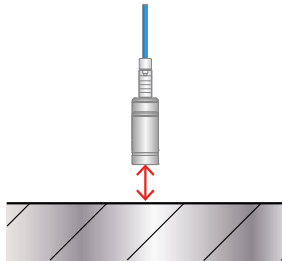

The capaNCDT system measures the capacitive reactance (X_c) of the capacitor, which varies proportionally with the distance.

Thickness measurement of electrically conductive materials

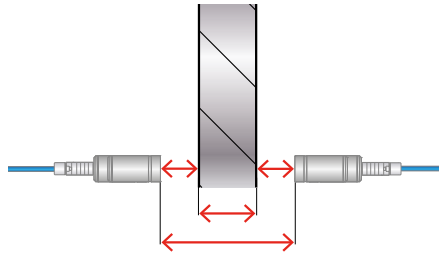

To measure the thickness of electrically conductive materials, two sensors are mounted on opposite sides. Each sensor measures the distance to the surface of the object being measured. The material thickness is simply calculated based on the known distance between the sensors.

Measurement of the gap between electrically conductive surfaces

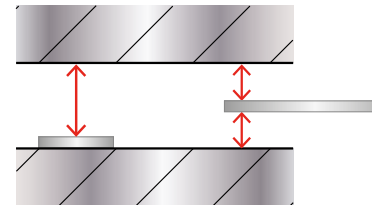

Gap measurement determines the distance between two electrically conductive materials. The sensor measures the distance from one side to the other, taking its own thickness into account, or - when freely suspended - the distance to both sides, and uses this to calculate the corresponding gap width.

Successful applications in numerous industries

Energy technology



Air gap in the wind power generator

Semicon machine building

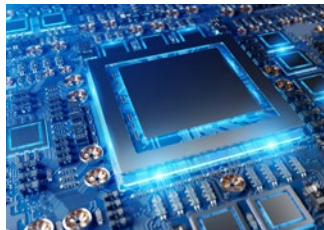

Chip testing systems

Measurement and testing



Creep test

Batteries

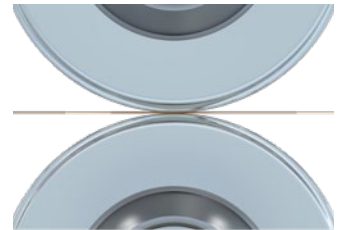

Roller gap in battery coating process



Monitoring in cryogenics



Chip bonding



Silicon photonics

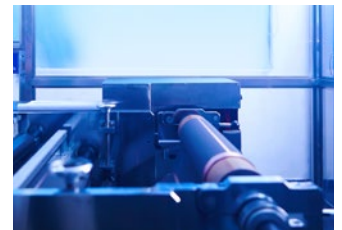

Battery film thickness

Extensive variety. Advanced technology. Globally leading.
capaNCDT

Innovative controller technology

- Easy operation via powerful web interface with calculation functions
- Numerous interfaces
- Industrial-grade and customizable

Multi-channel controller

- Modular systems with 1 to 8 channels
- Supports synchronization and calculation
- Non-contact grounding of the target object possible

Controller



capaNCDT 6100
 Compact single-channel system



capaNCDT 6200
 Modular multi-channel system



capaNCDT 6500
 Multi-channel system for highest resolution

Cables

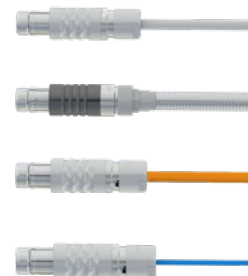

Application-specific models (more details from page 60)

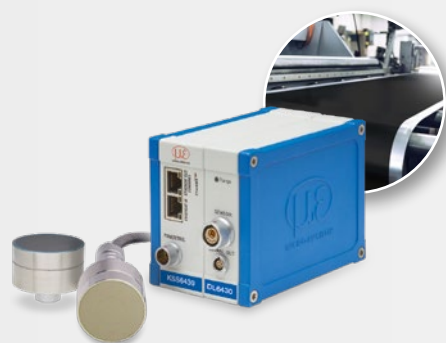

Coating thickness measurement of films and batteries
combiSENSOR

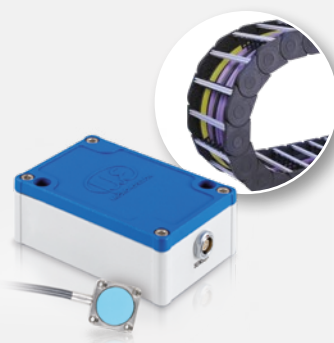

Active sensors for drag chains and long paths
capaNCDT 6114



Testing system for film thickness
capaNCDT TFG6220

Full compatibility and maximum precision

- Sensors, cables and controllers are compatible with each other
- Sensor replacement without re-calibration
- Optional linearity calibration (LC) for even greater precision

The right materials for every requirement – from laboratory to industry

- Particle-free, low-outgassing materials for cleanroom and vacuum applications
- Non-magnetic materials such as titanium and stainless steel for environments with strong magnetic fields
- Robust, temperature-resistant materials: mechanically stable for use at high and low temperatures

Sensors

- Max. cable length: 40 m
Standard 1.4 m / 2.8 m
- Industrial cable:
 - Crush-resistant with protective metal tubing
 - EMC resistant
 - Temperature-resistant up to +200 °C
 - Models for drag chain
- Cables for vacuum and cleanroom (low-outgassing)

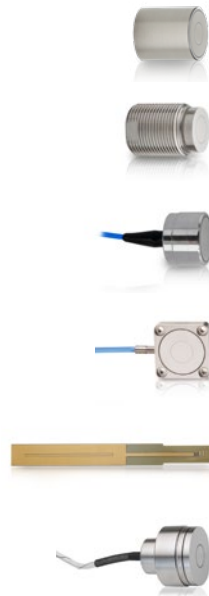

- Homogeneous measuring field and flush mounting due to additional guard electrode
- Robust sensors for extreme conditions, including cleanroom and UHV
- Ambient temperatures from -270 to +800 °C
- More than 50 standard sensors
- Measuring ranges from 0.05 mm to 10 mm
- Worldwide smallest sensor size
- A wide range of housing designs for every installation situation and mounting type
- Customer-specific modifications and OEM development



Rotational speed measurement
capaNCDT CST6110



Mobile gap measurement
capaNCDT MD6-22



Measurement of the brake disc thickness
capaNCDT DTV

More precision and stability

capaNCDT

✔ Maximum signal stability

Triaxial sensor design with active sensor cable

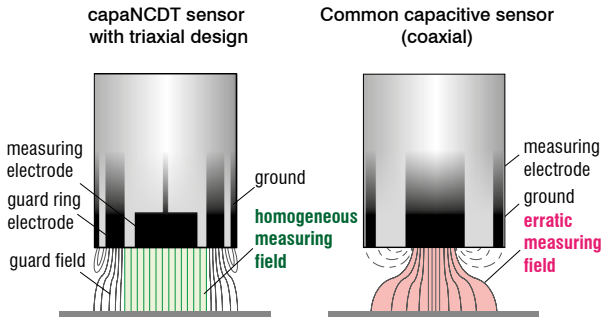

- Triaxial sensor design: measurement electrode, guard ring electrode and grounding
- Guard ring electrode ensures a homogeneous measuring field for precise measurements with highest signal stability
- Particularly low noise: electrically shielded sensor cable
- Highly precise – even when multiple sensors are arranged very close together
- Sensors with short-circuit safety

✔ Extensive range of applications

Widest portfolio of controllers and sensors

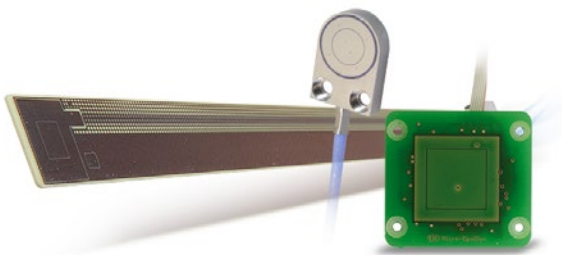

- All electrically conductive measuring objects: metals, alloys, CFRP, graphite, coatings
- No minimum thickness of the measuring object: an electrically conductive layer (e.g., 10 μm) is sufficient for measurement, e.g., vapor-deposited gold/metal layer
- Long distances possible: sensor cables up to 40 m
- Suitable for use on robots and in drag chains
- Various sensor models: flat/cylindrical/thread

✔ Unmatched precision

Nanometer precision with subnanometer resolution

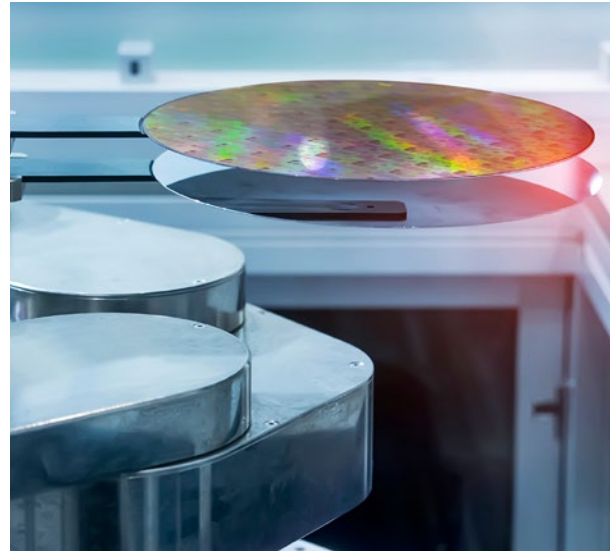

- High resolution from 0.015 nanometers
- Ultra-precision: linearity up to 200 nanometers
- Extremely reproducible
- Excellent long-term stability of $\pm 0.004\%$ FSO per month

✔ Easy integration into machines and straightforward retrofitting

Numerous interfaces and easy integration

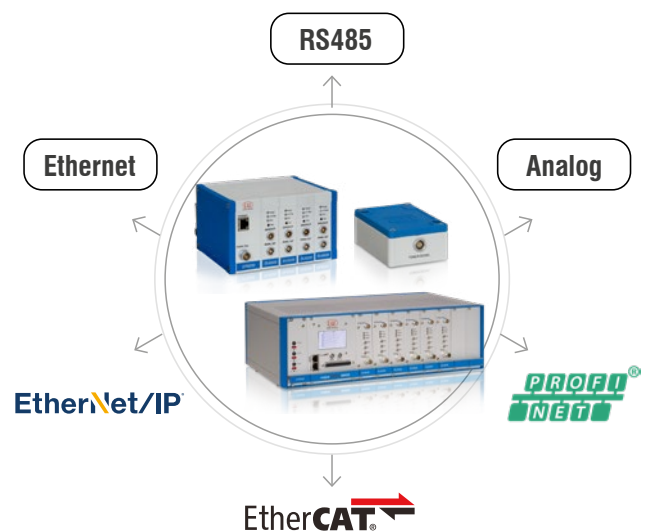

- Flexible integration due to industrial outputs: current, voltage, RS485, Ethernet and fieldbuses
- Secure mounting of the sensor and cable
- Simple installation concept requiring no special expertise
- Easy-to-clean sensor surfaces (CSF models)

✔ Miniature sensor sizes

Takes up very little space at the measuring point

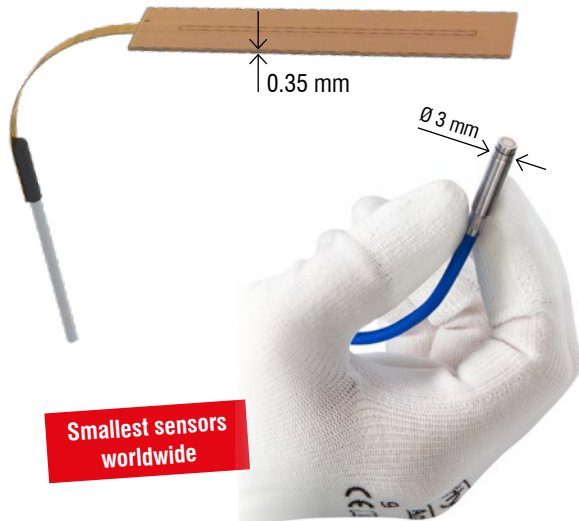

- No offset, measuring range starts directly at the sensor
- Integration in confined installation spaces with minimum effort
- Smallest diameters available with cylindrical sensors
- Extremely flat sensors available

✔ Applications in cleanroom and UHV

Passive and highly particle-free sensors

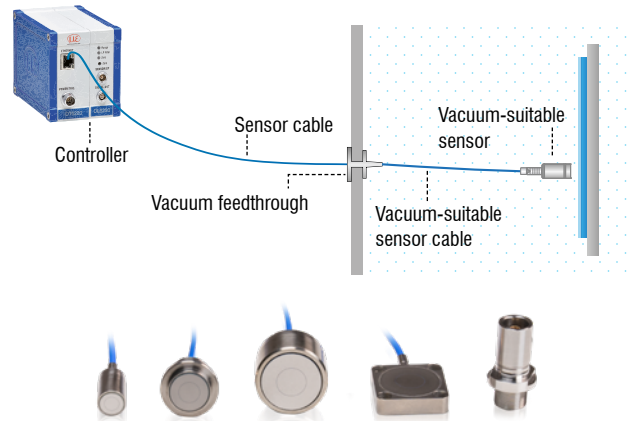

- No interactions between the sensor and the environment (e.g., force or heat transfer)
- Particle-free sensors and clean-room cables
- Special sensor design prevents virtual leaks
- Low-outgassing sensors (residual-gas analysis)
- Large selection of vacuum-compatible sensors, cables and feedthroughs

Get in touch with us so we can help you define the right components for your vacuum class.

✔ Measurement on moving parts

Virtual grounding of the measuring object

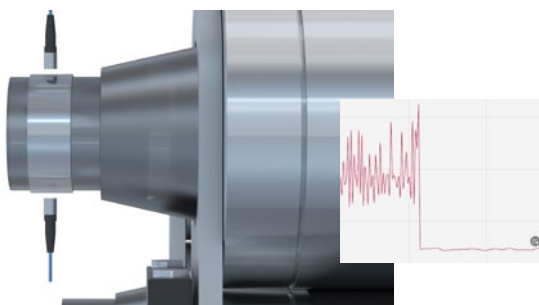

Capacitive multi-channel controllers with channel synchronization

- Stable and noise-free measurement results even on moving objects
- Enables electron dissipation, resulting in a smooth measurement signal

Resolution in the micrometer range

- Grounding of measuring object and controller recommended
- Or virtual grounding with multi-channel controllers

Resolution in the sub-micrometer range

- Grounding is absolutely necessary

✔ Built for durability in any environment

Highest signal stability in large temperature ranges

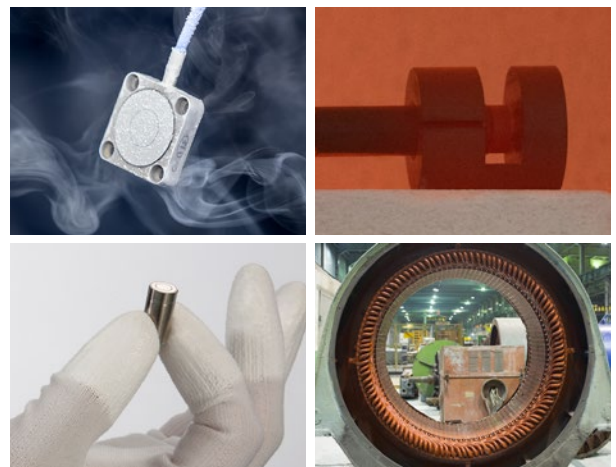

- Vacuum and cleanroom applications
- Excellent temperature stability of 5 ppm
- Use at very high and low temperatures from -270 to +800 °C
- Use in strong magnetic fields and high pressure

Flexible solutions from standard to OEM

capaNCDT

Design and characteristics of capacitive measuring systems

Capacitive measuring systems from Micro-Epsilon consist of at least three components:

- Sensor with socket/sensor with integrated cable
- Sensor cable
- ▪ Controller (consisting of oscillator, microcontroller and demodulator)
- Connection cables

Depending on the measurement task, the following components are added:

- Preamplifier, e.g. for long cable routes
- Vacuum feedthrough
- ▪ Special/extension cables

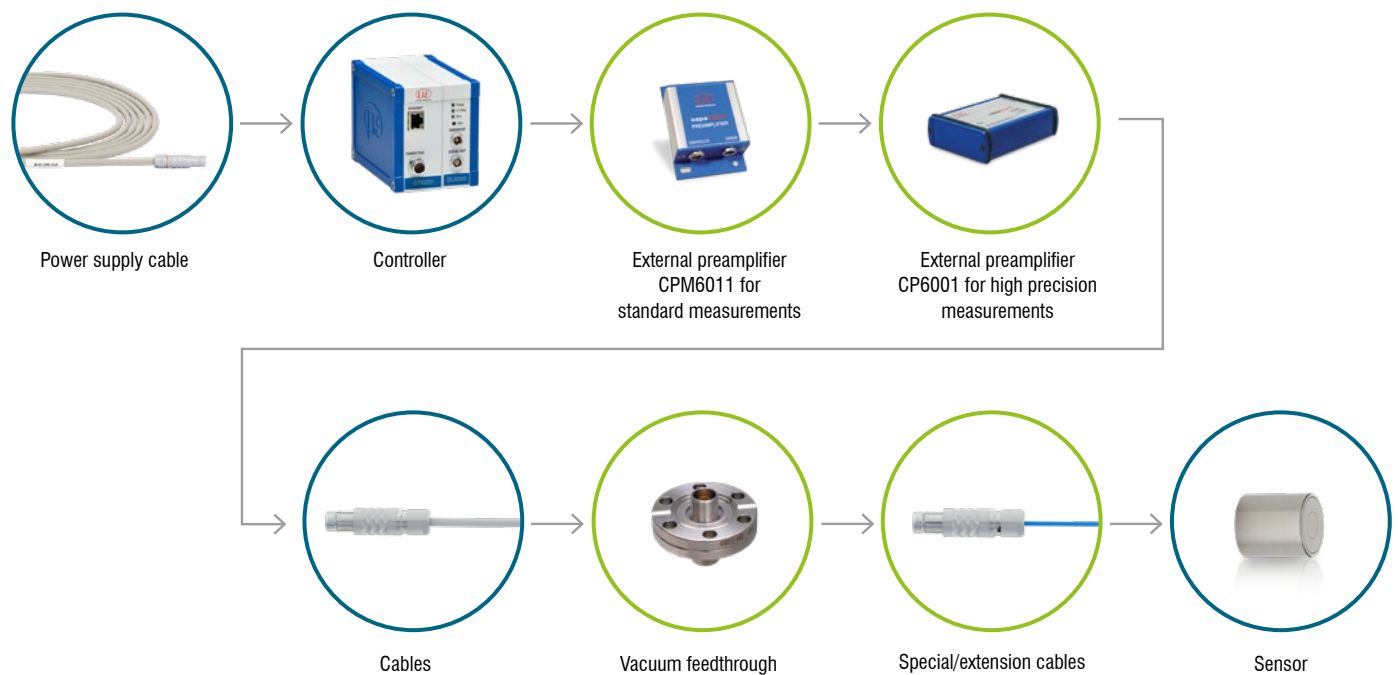

The full compatibility of all system components enables numerous combinations:

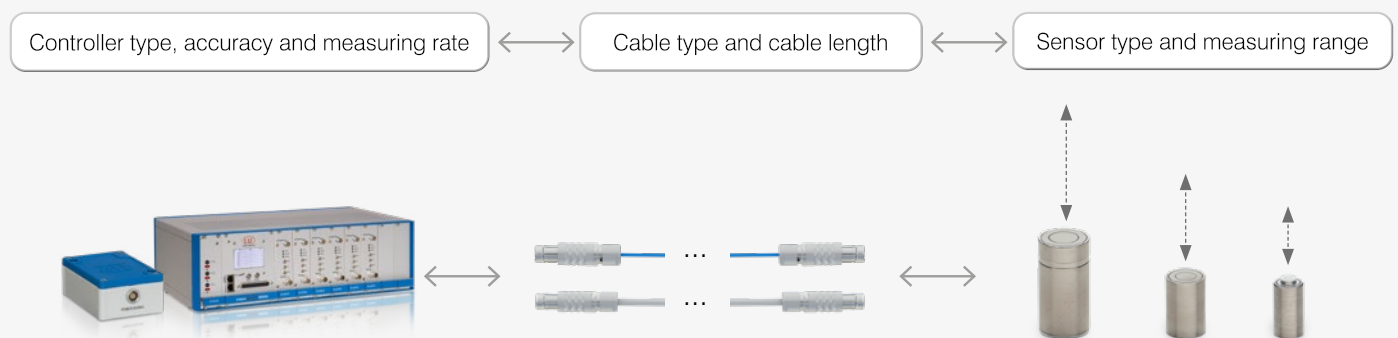

Specific sensors for OEM

When standard solutions reach their limits, we tailor our sensors and controllers to your specific requirements.

Frequently asked modifications include:

- Adapted design
- Target-specific adaptation
- Mounting options
- Individual cable lengths
- Modified measuring ranges
- Sensors with pre-installed controller
- Output types and interfaces



Application examples

capaNCDT

Wafer stage positioning

Capacitive sensors measure the position of the stage at various points, which is required in particular for fine alignment. Thanks to their triaxial design, the sensors are insensitive to electromagnetic fields and achieve a resolution in the nanometer range. They also achieve extremely high long-term stability. The sensors are designed for vacuum applications and can be used up to ultra-high vacuum.

Measuring system: capaNCDT 6200 with CSH/SE-sensors

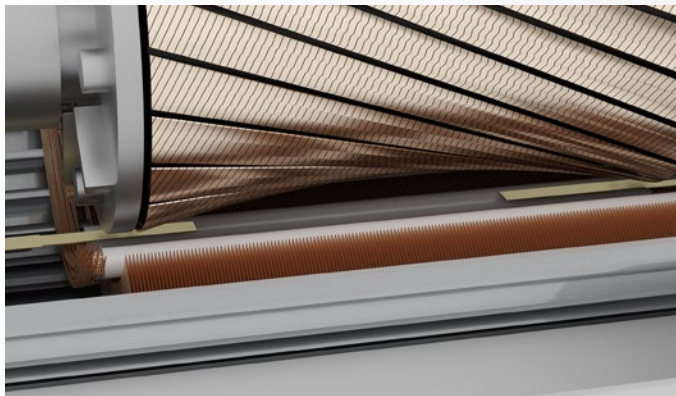
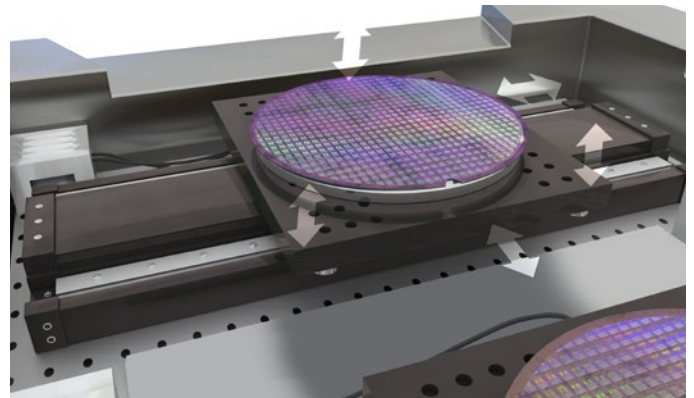

Air gap in generators and electric motors

Capacitive sensors measure the air gap between a rotor and a stator. Thanks to their small and flat design, they are easy to integrate and can also be used in confined installation spaces such as electric motors. The sensors are used both on test benches and permanently integrated into the motor or generator. For service purposes, sensors measuring on both sides can also be inserted manually into the gap.

Measuring system: capaNCDT DT6200 with CSG & CSF sensors

Expansion of battery cells during initial charging

At the end of the battery cell production process, the cell undergoes a functional and quality test. This is carried out during the battery's initial charging process. During charging, the expansion of the cell is monitored by a capacitive sensor with high resolution and micrometer accuracy. In combination with additional measured variables, such as pressure, conclusions can be drawn about quality and safety.

Measuring system: capaNCDT 6200 with CS sensors

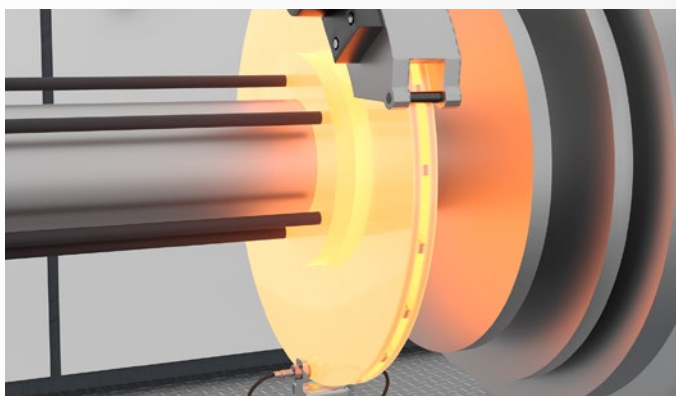
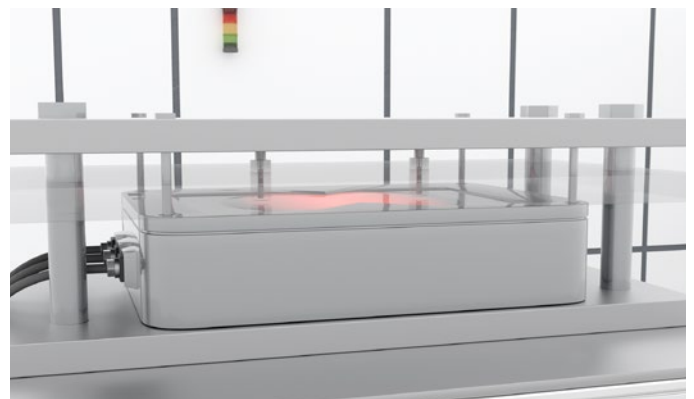

Thickness measurement of brake discs

Capacitive high-temperature sensors enable non-contact measurement of brake disc runout, deformation, and disc thickness variation. They are used on test benches, in road tests, and in workshops.

Measuring system: capaNCDT 6229(02)/DTV with CSE/HT sensors

Roller gap measurement in calendering processes

In calendering processes, such as battery film production, strip materials are rolled to an exact thickness. To ensure precise control of this process, it is not the material itself that is measured, but the gap between the calender rolls. Special capacitive gap sensors provide highly precise gap measurement.

Measuring system: capaNCDT 6200 with CSG sensors

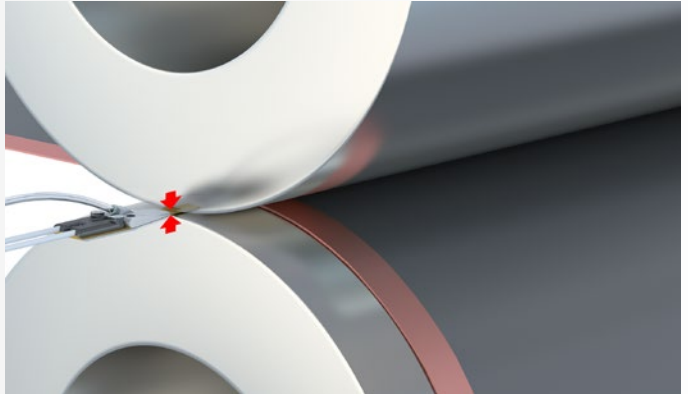

Mask positioning in lithography

Capacitive displacement sensors are used for the highly precise alignment and long-term stable monitoring of lithography masks. The sensors measure the z-position of air- or magnetically levitated masks so that the correct height is maintained with nanometer precision. The multi-channel controllers also provide virtual grounding of the target object via four sensors.

Measuring system: capaNCDT 6500 with CSH-FL sensors

Powder bed height in 3D printing

In metal 3D printing and laser sintering, precision components are built up from many thin powder layers. To ensure high component quality, these layers must be applied uniformly and evenly. Capacitive sensors integrated into the build platform precisely monitor the small movements as the platform is lowered and the next powder layer is applied. At the same time, the blade used to spread the powder layer is aligned with high precision, and the height of the powder bed is determined with micrometer accuracy.

Measuring system: capaNCDT 6100 with CS sensors

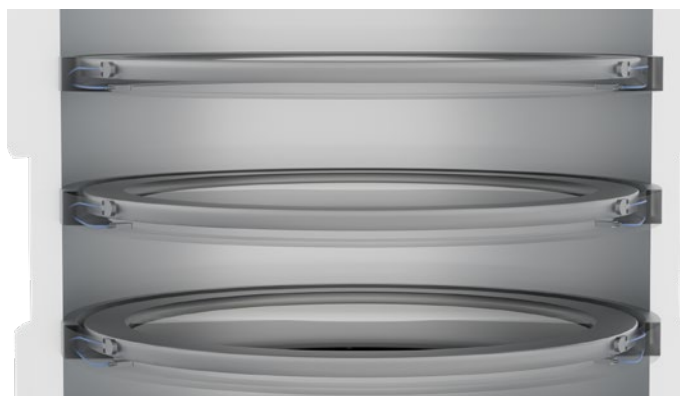
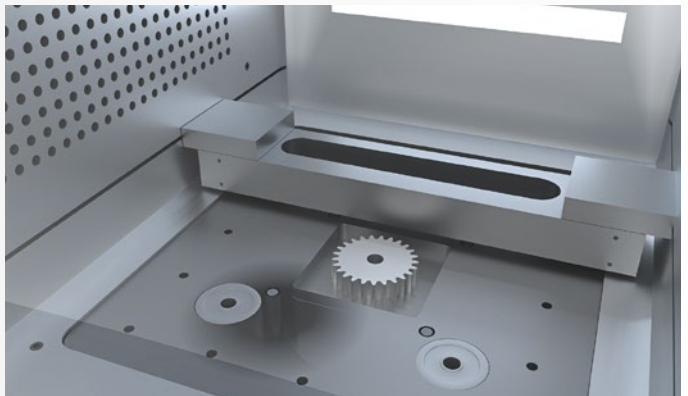

Alignment of lenses and optical systems

Capacitive displacement sensors are used for the alignment and fine positioning of mounted lenses. The lenses must be positioned precisely in the beam path of an optical unit, for example in a lithography machine. The lateral distance in X and Y is measured by the capacitive sensors with nanometer accuracy. Piezo actuators then move the lens into the required position.

Measuring system: capaNCDT 6200 with CSH/SE flat sensors

Capacitive sensors

Best practices for optimal measurements

A capacitive sensor measures the distance to an object based on the change in electrical capacitance between two electrodes. The two electrodes are formed by the sensor and the opposing measuring object. If a constant alternating current flows through the sensor, the amplitude of the AC voltage at the sensor is directly proportional to the distance between the two electrodes. In addition to the measuring principle, other physical properties and relationships must also be taken into account when selecting a sensor, as briefly explained below.



Minimum size of the measuring object

The capaNCDT sensors generate their measurement results from a measurement spot. The size of this spot is decisive for the size of the target object, and vice versa. For precise and stable measurements, the minimum size of a flat target object must be maintained, or a special factory calibration must be carried out. Recommendations for target object size can be found in the technical data and on pages 58 and 59.

Measuring range and sensor size

The capacitive measuring principle is based on the direct relationship between the measuring range, sensor size and measurement spot. This means that larger measuring ranges require larger housings, which results in a larger measurement spot. The sensor's measuring range starts directly at the measurement area (at "0") and extends up to the end of its calibrated measuring range (max. 20 mm with the CS-10/B).

Linearity and resolution

The resolution values specified in the technical data describe a static and a dynamic application. The values were recorded with the DT6530 controller at 2 Hz (static resolution) and 8.5 kHz (dynamic resolution). If a different controller or a different measuring rate is used, the resolution also changes (see figure on page 40).

The same applies to linearity, which describes the accuracy of the sensor. The value depends on the controller and must be added to the controller linearity. To optimize linearity, an additional linearity calibration can be carried out at the factory.

"Replacement accuracy": This value indicates the linearity achieved after replacement (without recalibration).

Maximum versatility for every application

Micro-Epsilon offers the world's leading portfolio of sensors, featuring a wide range of standard and custom models for various applications.

Depending on the operating conditions, various housing and potting materials are used, including:

- Special alloys (e.g. Inconel) for high temperatures
- Stainless steel for cleanroom/vacuum
- Titanium for applications in strong magnetic fields
- Invar for highest temperature stability

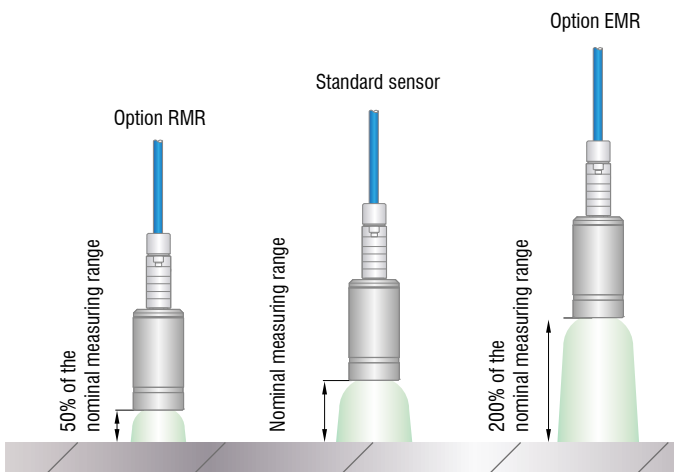
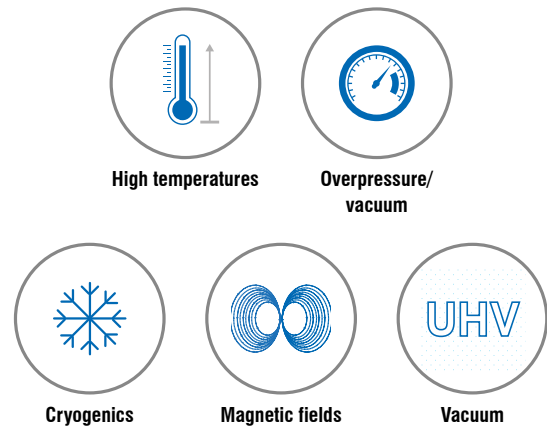

Extension and reduction of the measuring range

To increase the sensors' flexibility, their measuring ranges can be extended by a factor of 2 or reduced by a factor of 0.5 through factory calibration of the controller.

You can find the corresponding measuring ranges in the technical specifications under "reduced" or "extended". This allows existing sensor designs to be used for larger measuring ranges or to improve measurement accuracy by reducing the measuring range.

Optimal mounting for maximum temperature stability

Capacitive sensors from Micro-Epsilon are mounted in different ways depending on their design. In most cases, installation is done using a circumferential clamp or a clamp secured with a set screw. However, some sensors can also be screwed in place, either directly using a thread in the housing or with mounting screws.

In the technical data, you will find the specifications for the "Recommended mounting position". This indicates the optimal mounting or clamping point at which maximum temperature stability, and thus the highest possible precision, is achieved.

This is followed by the clamping area, where clamping fastening is possible.

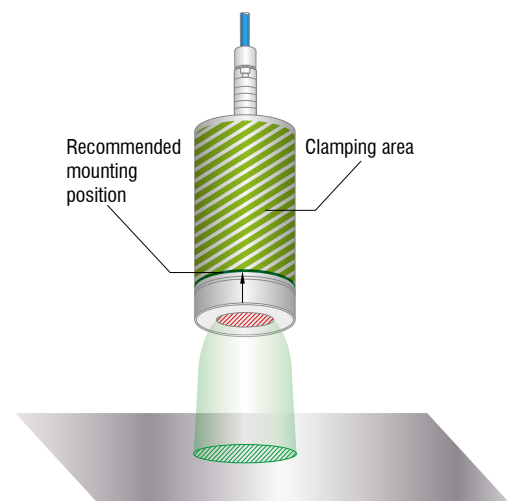

Cylindrical standard sensors (socket)

capaNCDT CSx /CS-x



Model		CS005	CS02	CS08
Measuring range	Reduced	0.025 mm	0.1 mm	0.4 mm
	Nominal	0.05 mm	0.2 mm	0.8 mm
	Extended	0.1 mm	0.4 mm	1.6 mm
Resolution ^[1]	Static	0.015 nm	0.06 nm	0.24 nm
	Dynamic	1 nm	4 nm	16 nm
Linearity ^[2]		< ±0.2 μm	< ±0.4 μm	< ±0.24 μm
Replaceability ^[3]		< ±0.5 % FSO	< ±0.3 % FSO	< ±0.3 % FSO
Temperature stability ^[4]		-0.01 μm / K	-0.01 μm / K	-0.03 μm / K
Recommended target size (flat) ^[5]		Ø 3 mm	Ø 5 mm	Ø 9 mm
Active measuring area		Ø 1.3 mm	Ø 2.6 mm	Ø 4.9 mm
Connection ^[6]		Plug connection via triaxial socket (type C)		
Temperature range	Storage	-50 ... 200 °C		
	Operation	-50 ... 200 °C		
Shock (DIN EN 60068-2-27)		30g / 5 ms in XY axis, 1000 shocks each		
Vibration (DIN EN 60068-2-6)		20 g / 58 ... 2000 Hz in XY axis, 10 cycles each		
Protection class (DIN EN 60529)		IP40		
Material		NiFe (magn.)		
Weight		approx. 2 g	approx. 2 g	approx. 7 g
Mounting		Circumferential clamping		
Recommended mounting position ^[7]		3 mm		
Compatibility		Compatible with all capacitive controllers from Micro-Epsilon Sensors can be replaced as required without recalibration (see replacement accuracy)		

^[1] RMS noise referred to the end of the measuring range and to the nominal measuring range using the standard cable CCm (1.4 m); valid for operation with the DT6530: static 2 Hz, dynamic 8.5 kHz

^[2] Typical linearity that must be added to the controller linearity; applies to standard cable tuning CCm (1.4 m)

^[3] FSO = Full Scale Output | The value corresponds to the slope error that occurs when a sensor is replaced without recalibration

^[4] In recommended mounting position; from a temperature of +150 °C: non-linear signal drift

^[5] In relation to the nominal measuring range

^[6] For suitable sensor cables, please refer to Connections

^[7] From the sensor front face (measuring surface), opposite to the measuring direction

Mounting the cylindrical sensors CSx and CS-x

CSx / CS-x cylindrical sensors can be installed either protruding (with the sensor extending beyond the mounting bracket) or flush with the mounting bracket. The sensor is mounted either by point clamping using a plastic set screw or by circumferential clamping using a collet. When using circumferential clamps, please note that the surrounding material may cause heat buildup. CS-x series sensors with measuring ranges of ≤ 2 mm have a mechanically defined clamping point (slightly wider housing).

The technical specifications always refer to circumferential clamping at the recommended mounting position.

Recommended mounting of CSx sensors



With set screw

With circumferential clamping



Model		CS-0,25/C	CS-0,5/C	CS-1/B	CS-2/B	CS-3/B	CS-5/B	CS-10/B
Measuring range	Reduced	0.125 mm	0.25 mm	0.5 mm	1 mm	1.5 mm	2.5 mm	5 mm
	Nominal	0.25 mm	0.5 mm	1 mm	2 mm	3 mm	5 mm	10 mm
	Extended	0.5 mm	1 mm	2 mm	4 mm	6 mm	10 mm	20 mm
Resolution ^[1]	Static	0.075 nm	0.15 nm	0.3 nm	0.6 nm	0.9 nm	1.5 nm	3 nm
	Dynamic	5 nm	10 nm	20 nm	40 nm	60 nm	100 nm	200 nm
Linearity ^[2]		< ±0.125 μm	< ±0.15 μm	< ±1 μm	< ±0.4 μm	< ±0.6 μm	< ±1 μm	< ±15 μm
Replaceability ^[3]		< ±0.5 % FSO	< ±0.3 % FSO	< ±0.2 % FSO	< ±0.2 % FSO	< ±0.2 % FSO	< ±0.2 % FSO	< ±0.2 % FSO
Temperature stability ^[4]		-0.015 μm/K	-0.025 μm/K	-0.035 μm/K	-0.13 μm/K	-0.3 μm/K	-0.35 μm/K	-0.5 μm/K
Recommended target size (flat) ^[5]		Ø 5 mm	Ø 7 mm	Ø 9 mm	Ø 17 mm	Ø 27 mm	Ø 37 mm	Ø 57 mm
Active measuring area		Ø 2.9 mm	Ø 3.9 mm	Ø 5.5 mm	Ø 7.9 mm	Ø 9.6 mm	Ø 12.5 mm	Ø 17.8 mm
Connection ^[6]		Plug connection via triaxial socket (type C)			Plug connection via triaxial socket (type B)			
Temperature range	Storage	-50 ... 200 °C						
	Operation	-50 ... 200 °C						
Shock (DIN EN 60068-2-27)		50 g / 5 ms in 6 directions, 1000 shocks each						
Vibration (DIN EN 60068-2-6)		30 g / 10 ... 2000 Hz in 3 axes 2.5 mm, 10 cycles each						
Protection class (DIN EN 60529)		IP40						
Material		NiFe (magn.)			1.4404 (non-magn.)			
Weight		approx. 1.8 g	approx. 3.6 g	approx. 7.7 g	approx. 45.6 g	approx. 64.2 g	approx. 91.3 g	approx. 179.1 g
Mounting		Circumferential clamping						
Recommended mounting position		at the defined clamping range (marking on the sensor)				on the mandrel (Ø 20 mm); 7.5 mm behind the sensor face		
Compatibility		Compatible with all capacitive controllers from Micro-Epsilon Sensors can be replaced as required without recalibration (see replacement accuracy)						

^[1] RMS noise referred to the end of the measuring range and to the nominal measuring range using the standard cable CCm (1.4 m); valid for operation with the DT6530: static 2 Hz, dynamic 8.5 kHz
^[2] Typical linearity that must be added to the controller linearity; applies to standard cable tuning CCm (1.4 m)
^[3] FSO = Full Scale Output | The value corresponds to the slope error that occurs when a sensor is replaced without recalibration
^[4] In recommended mounting position; from a temperature of +150 °C: non-linear signal drift
^[5] In relation to the nominal measuring range
^[6] For suitable sensor cables, please refer to Connections

Recommended mounting of CS-x sensors

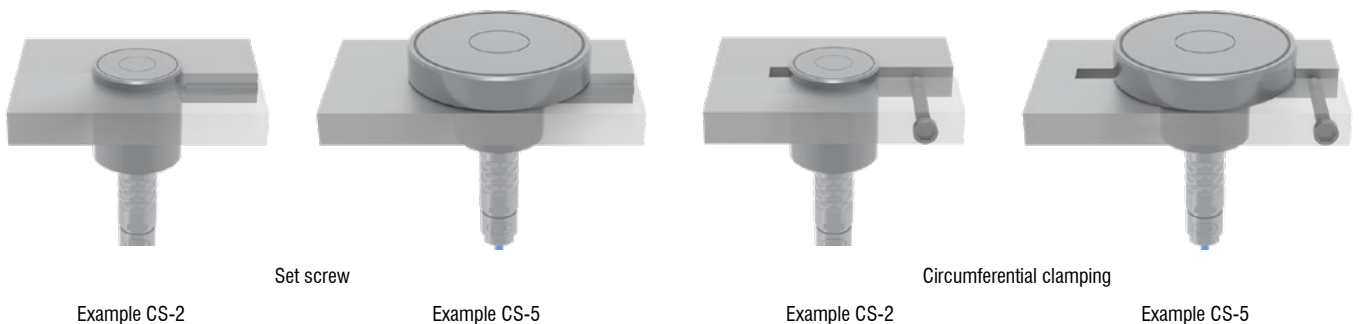

Dimensions

capaNCDT CSx /CS-x

CS005

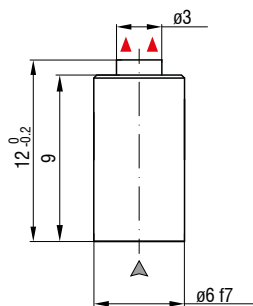

CS02

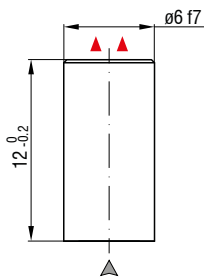

CS08

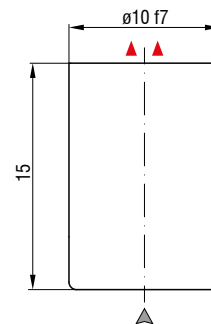

CS-0,25/C

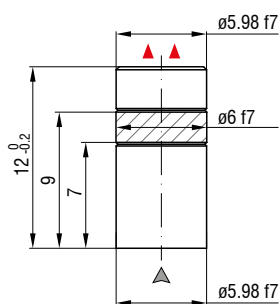

CS-0,5/C

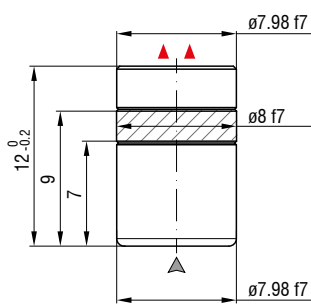

CS-1/B

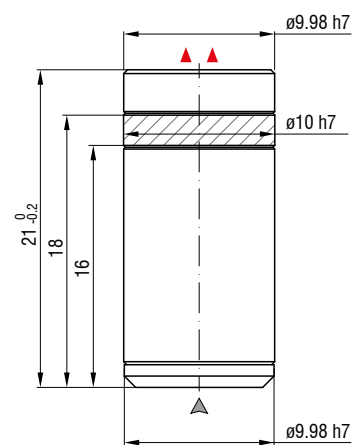

CS-2/B

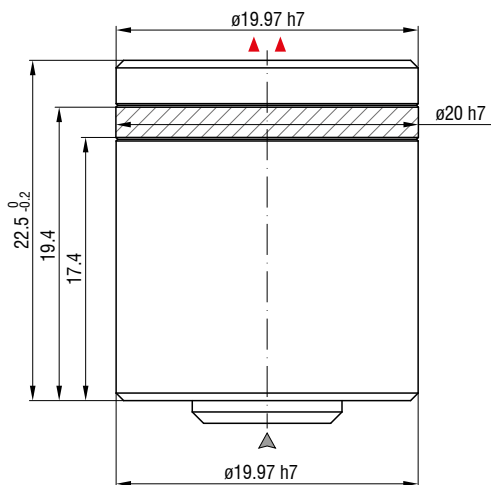

CS-3/B

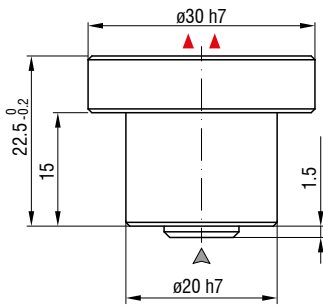

CS-5/B

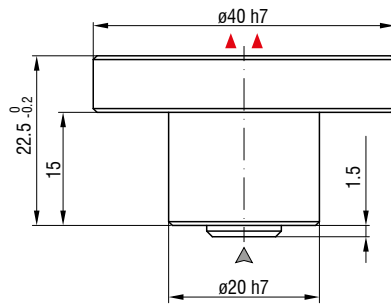

CS-10/B

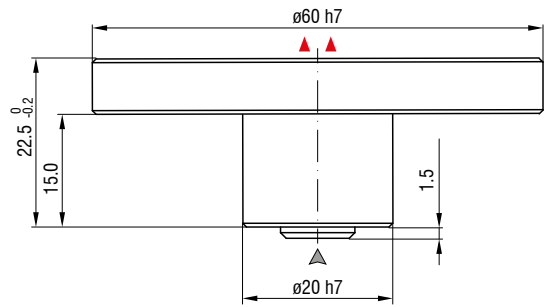

▲ ▲ Measurement direction

▲ Connector side

(dimensions in mm, not to scale)

Cylindrical sensors in very compact design (socket)

capaNCDT CSE



Model		CSE01-CAm1,4	CSE025-CAm1,4	CSE05	CSE1	CSE1.25	CSE2	CSE3
Measuring range	Reduced	0.05 mm	0.125 mm	0.25 mm	0.5 mm	0.625 mm	1 mm	1.5 mm
	Nominal	0.1 mm	0.25 mm	0.5 mm	1 mm	1.25 mm	2 mm	3 mm
	Extended	0.15 mm	0.5 mm	1 mm	2 mm	2.05 mm	4 mm	6 mm
Resolution ^[1]	Static	0.03 nm	0.075 nm	0.15 nm	0.3 nm	0.375 nm	0.6 nm	0.9 nm
	Dynamic	2 nm	5 nm	10 nm	20 nm	25 nm	40 nm	60 nm
Linearity ^[2]		< ±0.3 μm	< ±0.375 μm	< ±0.25 μm	< ±2 μm	< ±1.25 μm	< ±2 μm	< ±3 μm
Replaceability ^[3]		< ±0.5 % FSO	< ±0.5 % FSO	< ±0.2 % FSO	< ±0.2 % FSO	< ±0.2 % FSO	< ±0.2 % FSO	< ±0.2 % FSO
Temperature stability		-0.025 μm/K	-0.025 μm/K	-0.02 μm/K	-0.02 μm/K	-0.12 μm/K	-0.16 μm/K	-0.18 μm/K
Recommended target size (flat) ^[4]		Ø 3 mm	Ø 4 mm	Ø 6 mm	Ø 8 mm	Ø 10 mm	Ø 14 mm	Ø 20 mm
Active measuring area		Ø 1.8 mm	Ø 2.9 mm	Ø 3.9 mm	Ø 5.7 mm	Ø 6.5 mm	Ø 8 mm	Ø 9 mm
Connection ^[5]		integrated cable with connector (type B); standard length 1.4 m		Plug connection via triaxial socket (type C)		Plug connection via triaxial socket (type B)		
Mounting		Circumferential clamping						
Temperature range	Storage	-50 ... 200 °C						
	Operation	-50 ... 200 °C						
Shock (DIN EN 60068-2-27)		20 g / 5 ms in XY axis, 1000 shocks each			30g / 5 ms in XY axis, 1000 shocks each			
Vibration (DIN EN 60068-2-6)		10 g / 58 ... 2000 Hz in XY axis, 10 cycles each			20 g / 58 ... 2000 Hz in XY axis, 10 cycles each			
Protection class (DIN EN 60529)		IP40						
Material		NiFe (magn.)				1.4404 (non-magn.)		
Weight		approx. 26 g (incl. cable)	approx. 27 g (incl. cable)	approx. 2 g	approx. 3.5 g	approx. 8.2 g	approx. 20 g	approx. 50 g
Recommended mounting position ^[6]		2.5 mm	1.2 mm	3 mm	3 mm	3.5 mm	3.5 mm	4.5 mm
Compatibility		Compatible with all capacitive controllers from Micro-Epsilon Sensors can be replaced as required without recalibration (see replacement accuracy)						

^[1] RMS noise referred to the end of the measuring range and to the nominal measuring range using the standard cable CCm (1.4 m); valid for operation with the DT6530: static 2 Hz, dynamic 8.5 kHz

^[2] Typical linearity to be added to the controller linearity; valid for standard cable adjustment CCm (1.4 m)

^[3] FSO = Full Scale Output | The value corresponds to the slope error that occurs when a sensor is replaced without recalibration

^[4] In relation to the nominal measuring range

^[5] For suitable sensor cables, please refer to Connections

^[6] From the sensor front face (measuring surface), opposite to the measuring direction

Mounting of the cylindrical CSE sensors

CSE-type cylindrical sensors can be installed either protruding (with the sensor extending beyond the mounting bracket) or flush with the mounting bracket. However, when installing flush with the surface, a clearance must be taken into account. The sensor is mounted either by point clamping using a plastic set screw or by circumferential clamping using a collet. When using circumferential clamps, please note that the surrounding material may cause heat buildup. The technical specifications always refer to circumferential clamping at the recommended mounting position.

Recommended mounting of CSE sensors

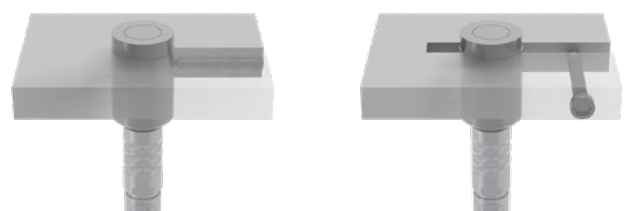

With set screw

With circumferential clamping

Dimensions

capaNCDT CSE

CSE01-CAm1,4

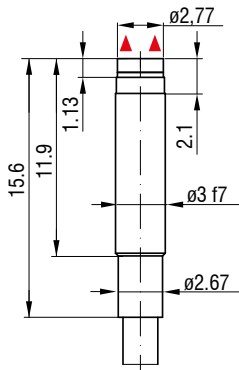

CSE025-CAm1,4

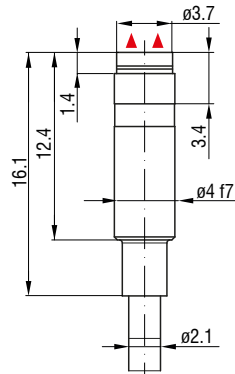

CSE05

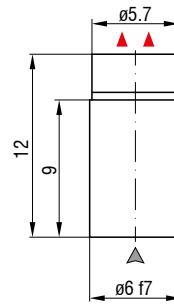

CSE1

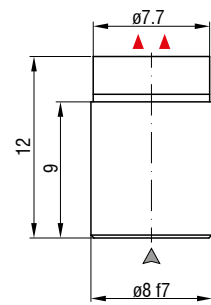

CSE1,25

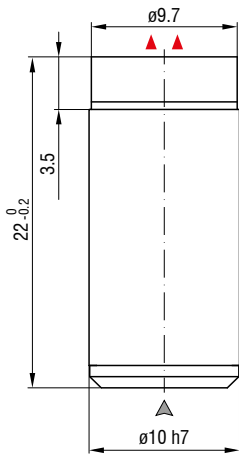

CSE2

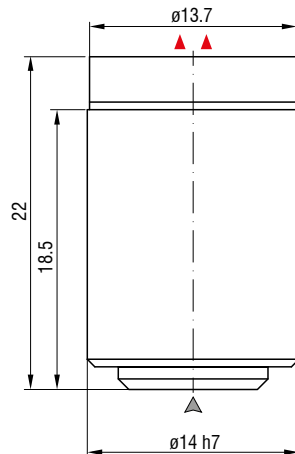

CSE3

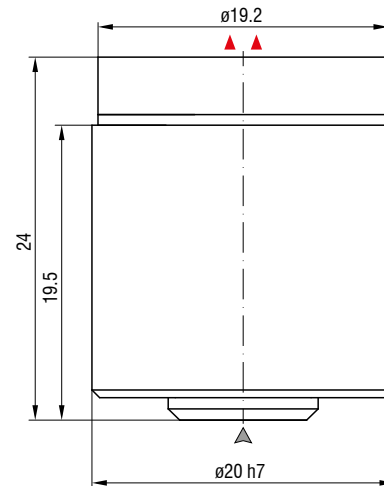

▲ ▲ Measurement direction

▲ Connector side

(dimensions in mm, not to scale)

Cylindrical sensors with thread (socket)

capaNCDT CSE/Mx

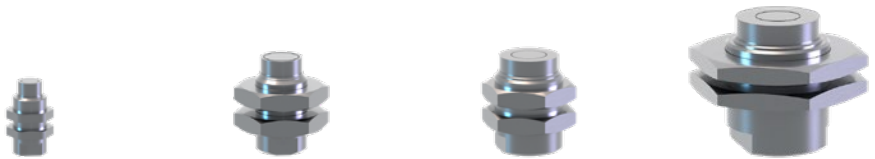

Model		CSE05/M8	CSE1.25/M12	CSE2/M16	CSE3/M24
Measuring range	Reduced	0.25 mm	0.625 mm	1 mm	1.5 mm
	Nominal	0.5 mm	1.25 mm	2 mm	3 mm
	Extended	1 mm	2.5 mm	4 mm	6 mm
Resolution ^[1]	Static	0.15 nm	0.375 nm	0.6 nm	0.9 nm
	Dynamic	10 nm	25 nm	40 nm	60 nm
Linearity ^[2]		< ±0.25 μm	< ±1.25 μm	< ±2 μm	< ±3 μm
Replaceability ^[3]		< ±0.2 % FSO	< ±0.2 % FSO	< ±0.2 % FSO	< ±0.2 % FSO
Temperature stability		-0.02 μm / K	-0.12 μm / K	-0.16 μm / K	-0.18 μm / K
Recommended target size (flat) ^[4]		Ø 6 mm	Ø 10 mm	Ø 14 mm	Ø 20 mm
Active measuring area		Ø 3.9 mm	Ø 6.3 mm	Ø 8 mm	Ø 9.8 mm
Connection ^[5]		Plug connection via triaxial socket (type C)		Plug connection via triaxial socket (type B)	
Mounting		Direct fastening via thread on the sensor			
Temperature range	Storage	-50 ... 200 °C			
	Operation	-50 ... 200 °C			
Shock (DIN EN 60068-2-27)		30g / 5 ms in XY axis, 1000 shocks each			
Vibration (DIN EN 60068-2-6)		20 g / 58 ... 2000 Hz in XY axis, 10 cycles each			
Protection class (DIN EN 60529)		IP40			
Material		NiFe (magn.)	1.4404 (non-magn.)		
Weight		approx. 3.5 g	approx. 11.5 g	approx. 35 g	approx. 80 g
Recommended mounting position ^[6]		3.6 mm	4.4 mm	4.4 mm	5.4 mm
Compatibility		Compatible with all capacitive controllers from Micro-Epsilon Sensors can be replaced as required without recalibration (see replacement accuracy)			

^[1] RMS noise referred to the end of the measuring range and to the nominal measuring range using the standard cable CCm (1.4 m); valid for operation with the DT6530: static 2 Hz, dynamic 8.5 kHz

^[2] Typical linearity to be added to the controller linearity; valid for standard cable adjustment CCm (1.4 m)

^[3] FSO = Full Scale Output | The value corresponds to the slope error that occurs when a sensor is replaced without recalibration

^[4] In relation to the nominal measuring range

^[5] For suitable sensor cables, please refer to Connections

^[6] From the sensor front face (measuring surface), opposite to the measuring direction

Mounting of CSE/Mx thread sensors

The threaded sensors can be secured in an internal thread using a mounting nut (at the front or rear). For thin brackets and through-holes, the sensors are secured on both sides using two mounting nuts. Follow the tightening torques specified in the operating instructions.

The technical specifications always refer to circumferential clamping at the recommended mounting position.

Recommended mounting of CSE/Mx sensors

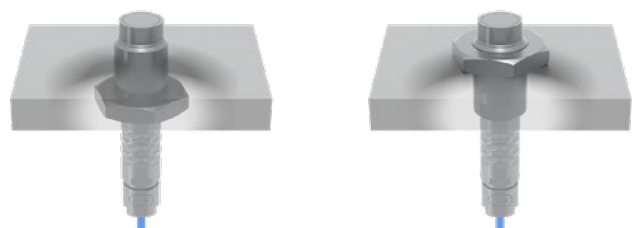

Back-secured with nut

Front-secured with nut

Dimensions

capaNCDT CSE/Mx

CSE05/M8

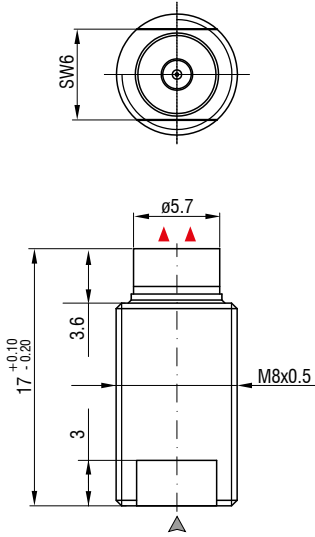

CSE1.25/M12

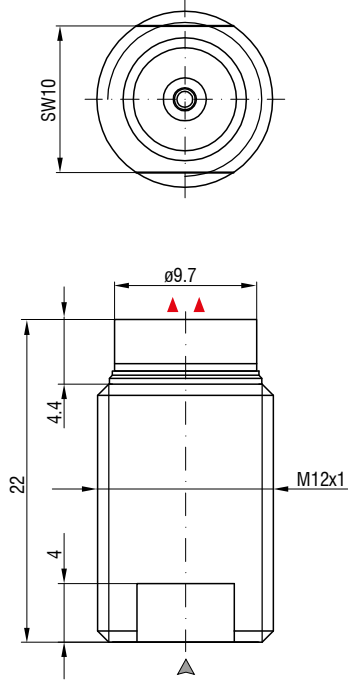

CSE2/M16

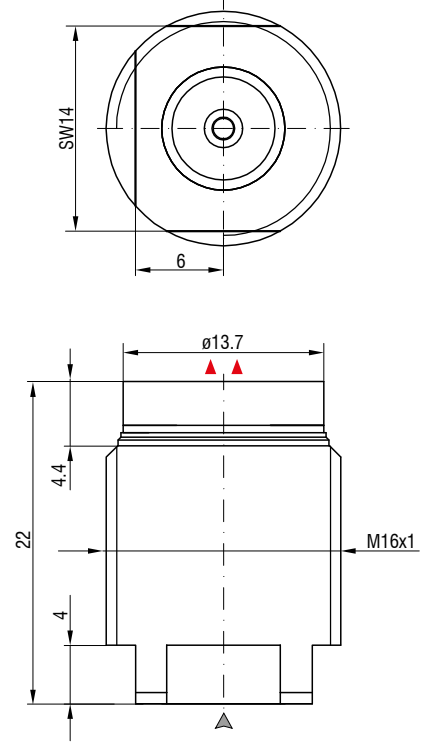

CSE3/M24

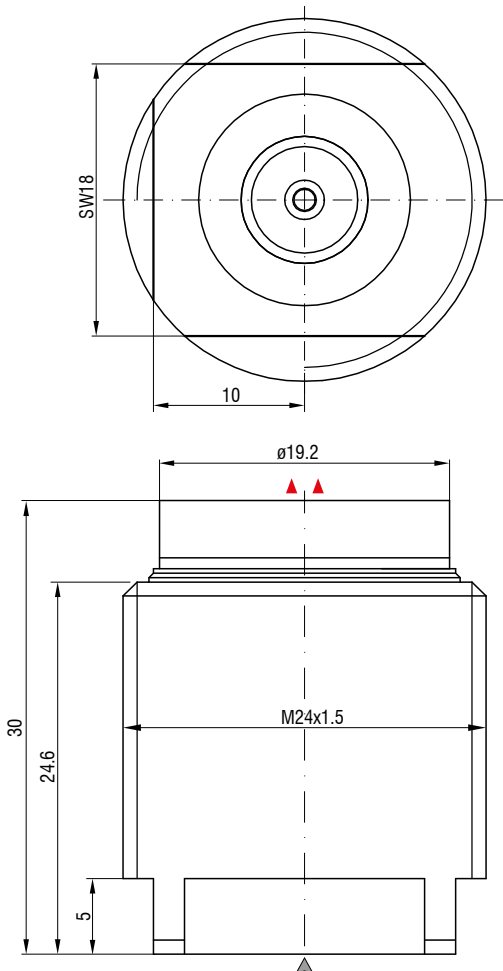

▲ ▲ Measurement direction

▲ Connector side

(dimensions in mm, not to scale)

High-precision cylindrical sensors (integrated cable)

capaNCDT CSH



Model		CSH02-CAm1,4	CSH05-CAm1,4	CSH1-CAm1,4	CSH1,2-CAm1,4	CSH2-CAm1,4
Measuring range	Reduced	0.1 mm	0.25 mm	0.5 mm	0.6 mm	1 mm
	Nominal	0.2 mm	0.5 mm	1 mm	1.2 mm	2 mm
	Extended	0.4 mm	1 mm	2 mm	2.4 mm	4 mm
Resolution ^[1]	Static	0.06 nm	0.15 nm	0.3 nm	0.36 nm	0.6 nm
	Dynamic	4 nm	10 nm	20 nm	24 nm	40 nm
Linearity ^[2]		< ±0.08 μm	< ±0.35 μm	< ±0.6 μm	< ±1.2 μm	< ±0.6 μm
Replaceability ^[3]		< ±0.5 % FSO	< ±0.2 % FSO	< ±0.2 % FSO	< ±0.2 % FSO	< ±0.2 % FSO
Temperature stability ^[4]		-0.01 μm / K	+0.01 μm / K	+0.056 μm / K	+0.052 μm / K	+0.152 μm / K
Recommended target size (flat) ^[5]		Ø 7 mm	Ø 7 mm	Ø 11 mm	Ø 11 mm	Ø 17 mm
Active measuring area		Ø 2.6 mm	Ø 4.1 mm	Ø 5.7 mm	Ø 6.3 mm	Ø 8.1 mm
Connection		integrated cable with connector (type B); standard length 1.4 m				
Mounting		Circumferential clamping				
Temperature range	Storage	-50 ... 200 °C				
	Operation	-50 ... 200 °C				
Shock (DIN EN 60068-2-27)		30g / 5 ms in XY axis, 1000 shocks each				
Vibration (DIN EN 60068-2-6)		20 g / 58 ... 2000 Hz in XY axis, 10 cycles each				
Protection class (DIN EN 60529)		IP40				
Material		1.4104 (magn.)				
Weight		approx. 30 g (incl. cable)	approx. 30 g (incl. cable)	approx. 33 g (incl. cable)	approx. 33 g (incl. cable)	approx. 38 g (incl. cable)
Recommended mounting position ^[6]		3 mm				
Compatibility		Compatible with all capacitive controllers from Micro-Epsilon Sensors can be replaced as required without recalibration (see replacement accuracy)				

^[1] RMS noise referred to the end of the measuring range and to the nominal measuring range using the standard cable CCm (1.4 m); valid for operation with the DT6530: static 2 Hz, dynamic 8.5 kHz

^[2] Typical linearity to be added to the controller linearity; valid for standard cable adjustment CCm (1.4 m)

^[3] FSO = Full Scale Output | The value corresponds to the slope error that occurs when a sensor is replaced without recalibration

^[4] In recommended mounting position; from a temperature of +120 °C: non-linear signal drift

^[5] In relation to the nominal measuring range

^[6] From the sensor front face (measuring surface), opposite to the measuring direction

Mounting of cylindrical CSH sensors

CSH-type cylindrical sensors can be installed either protruding (with the sensor extending beyond the mounting bracket) or flush with the mounting bracket. The sensor is mounted either by point clamping using a plastic set screw or by circumferential clamping using a collet. When using circumferential clamps, please note that the surrounding material may cause heat buildup.

The technical specifications always refer to circumferential clamping at the recommended mounting position.

Recommended mounting of CSH sensors



With set screw

With circumferential clamping

CSH02-CAm1,4

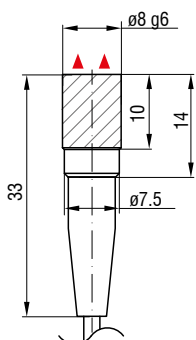

CSH05-CAm1,4

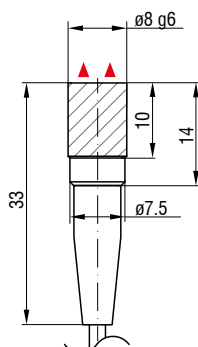

CSH1-CAm1,4

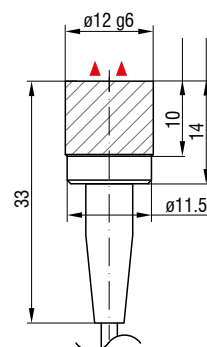

CSH1,2-CAm1,4

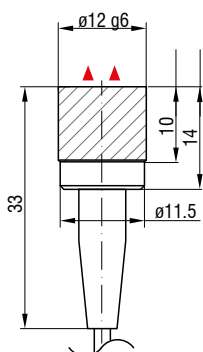

CSH2-CAm1,4

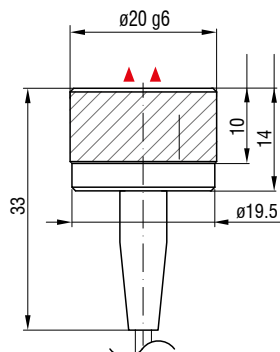

▲ ▲ Measurement direction

(dimensions in mm, not to scale)

Flat sensors (integrated cable)

capaNCDT CSHxFL

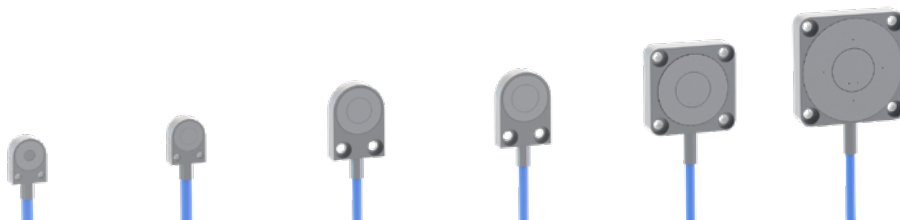

Model		CSH-02FL-CRm1,4	CSH-05FL-CRm1,4	CSH1FL-CRm1,4	CSH1,-2FL-CRm1,4	CSH2FL-CRm1,4	CSH3FL-CRm1,4
Measuring range	Reduced	0.1 mm	0.25 mm	0.5 mm	0.6 mm	1 mm	1.5 mm
	Nominal	0.2 mm	0.5 mm	1 mm	1.2 mm	2 mm	3 mm
	Extended	0.4 mm	1 mm	2 mm	2.4 mm	4 mm	6 mm
Resolution ^[1]	Static	0.06 nm	0.15 nm	0.3 nm	0.36 nm	0.6 nm	0.9 nm
	Dynamic	4 nm	10 nm	20 nm	24 nm	40 nm	60 nm
Linearity ^[2]		< ±0.08 μm	< ±0.35 μm	< ±0.6 μm	< ±1.2 μm	< ±0.6 μm	< ±1.5 μm
Replaceability ^[3]		< ±0.5 % FSO	< ±0.2 % FSO	< ±0.2 % FSO	< ±0.2 % FSO	< ±0.2 % FSO	< ±0.2 % FSO
Temperature stability ^[4]	Front-side mounting	+0.03 μm/K	+0.025 μm/K	+0.03 μm/K	+0.035 μm/K	+0.07 μm/K	+0.09 μm/K
	Rear-side mounting	-0.012 μm/K	-0.017 μm/K	-0.012 μm/K	+0.006 μm/K	+0.018 μm/K	+0.038 μm/K
Recommended target size (flat) ^[5]		Ø 7 mm	Ø 7 mm	Ø 11 mm	Ø 11 mm	Ø 17 mm	Ø 24 mm
Active measuring area		Ø 2.6 mm	Ø 4.1 mm	Ø 5.7 mm	Ø 6.3 mm	Ø 8.1 mm	Ø 10 mm
Connection		integrated cable with connector (type B); standard length 1.4 m					
Mounting		2 x M2 thread		2 x through hole for M2 screw		4 x through hole for M2 screw	
Temperature range	Storage	-50 ... 200 °C					
	Operation	-50 ... 200 °C					
Shock (DIN EN 60068-2-27)		30g / 5 ms in XY axis, 1000 shocks each					
Vibration (DIN EN 60068-2-6)		20 g / 58 ... 2000 Hz in XY axis, 10 cycles each					
Protection class (DIN EN 60529)		IP40					
Material		1.4104 (magn.)					
Weight		approx. 28 g (incl. cable)	approx. 28 g (incl. cable)	approx. 30 g (incl. cable)	approx. 30 g (incl. cable)	approx. 37 g (incl. cable)	approx. 37 g (incl. cable)
Compatibility		Compatible with all capacitive controllers from Micro-Epsilon Sensors can be replaced as required without recalibration (see replacement accuracy)					

^[1] RMS noise referred to the end of the measuring range and to the nominal measuring range using the standard cable CCm (1.4 m); valid for operation with the DT6530: static 2 Hz, dynamic 8.5 kHz

^[2] Typical linearity to be added to the controller linearity; valid for standard cable adjustment CCm (1.4 m)

^[3] FSO = Full Scale Output | The value corresponds to the slope error that occurs when a sensor is replaced without recalibration

^[4] at temperatures of +120 °C and above: non-linear signal drift

^[5] In relation to the nominal measuring range

Mounting of CSH/FL sensors

The flat sensors are mounted using a threaded hole for M2 screws (for the CSH02FL and CSH05FL sensors) or a through-hole for M2 screws. The sensors can be screwed on from above or below.

Recommended mounting of CSH/FL sensors



Top screw connection on the underside of the sensor



Screw mounting from below on the top side of the sensor (CSH02FL - CSH1.2FL)

Dimensions

capaNCDT CSHxFL

CSH02FL-CRm1,4

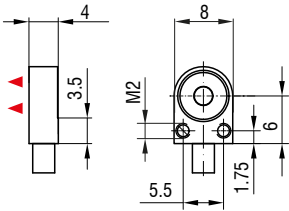

CSH05FL-CRm1,4

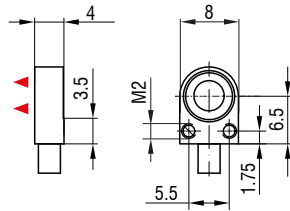

CSH1FL-CRm1,4

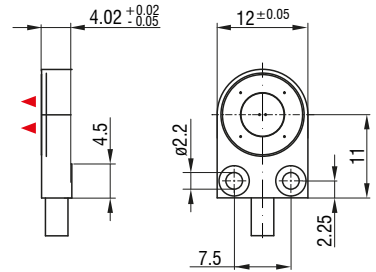

CSH1,2FL-CRm1,4

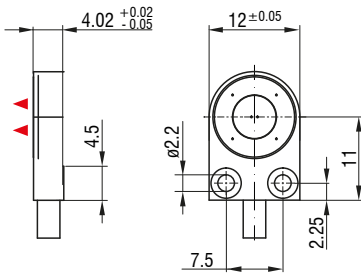

CSH2FL-CRm1,4

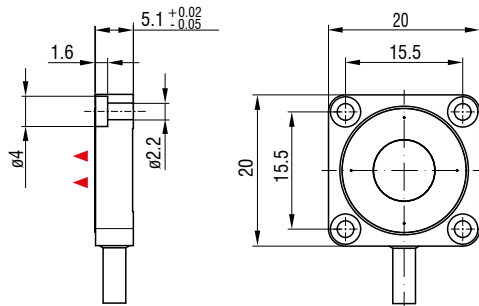

CSH3FL-CRm1,4

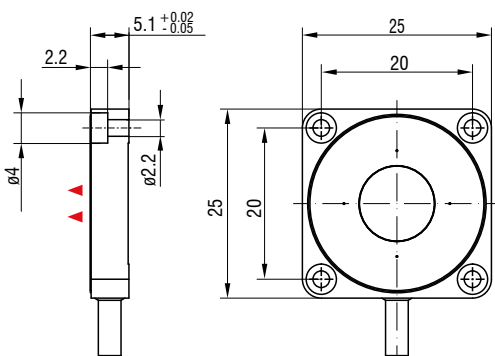

▲ ▲ Measurement direction

(dimensions in mm, not to scale)

Gap sensors for two-sided measurements

capaNCDT CSG

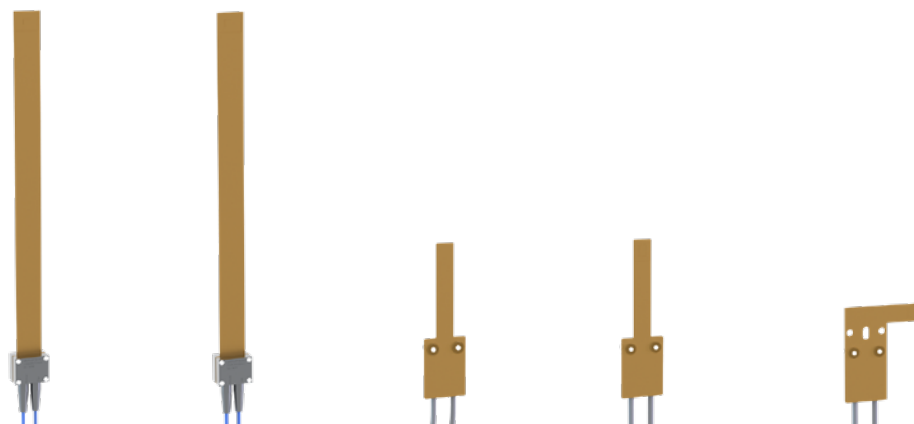

Model		CSG0,50-CAm2,0	CSG1,00-CAm2,0	CSG-0.5/CRg2,0	CSG-1/CRg2,0	CSG-1/90/CRg-2,0
Measuring range	Reduced	0.25 mm	0.5 mm	0.25 mm	0.5 mm	0.5 mm
	Nominal	0.5 mm	1 mm	0.5 mm	1 mm	1 mm
	Extended	1 mm	2 mm	1 mm	2 mm	2 mm
Resolution ^[1]	Static	0.15 nm	0.3 nm	0.15 nm	0.3 nm	0.3 nm
	Dynamic	10 nm	20 nm	10 nm	20 nm	20 nm
Linearity ^[2]		< ±0.5 μm	< ±1 μm	< ±1 μm	< ±2 μm	< ±2 μm
Replaceability ^[3]		< ±1.0 % FSO	< ±1.0 % FSO	< ±1.5 % FSO	< ±1.0 % FSO	< ±1.0 % FSO
Temperature stability		-0.08 μm/K	-0.1 μm/K	-0.2 μm/K	-0.2 μm/K	-0.2 μm/K
Required gap width		≥ 0.9 mm				
Recommended target size (flat) ^[4]		approx. 9.9 x 15 mm		approx. 10 x 10 mm	approx. 12 x 12 mm	approx. 10 x 10 mm
Active measuring area		4.3 x 3.0 mm	6.2 x 4.2 mm	4.3 x 3.0 mm	4 x 6.5 mm	5.1 x 5.1 mm
Connection		integrated cable with connector (type B); standard length 2.0 m				
Mounting		Surface clamping		Screw mounting via 2x through holes, Ø 3.1 mm, for M3 screws		
Temperature range	Storage	-50 ... 100 °C		-20 ... 100 °C	-20 ... 80 °C	
	Operation	-50 ... 100 °C		-20 ... 100 °C	-20 ... 150 °C (sensor); -20 ... 80 °C (cable)	
Shock (DIN EN 60068-2-27)		30g / 5 ms in XY axis, 1000 shocks each				
Vibration (DIN EN 60068-2-6)		20 g / 58 ... 2000 Hz in XY axis, 10 cycles each				
Protection class (DIN EN 60529)		IP40				
Material		Hard tissue (GFRP)				
Weight		approx. 77 g (incl. cable)		approx. 80 g	approx. 90 g	approx. 130 g
Compatibility		Compatible with all capacitive controllers from Micro-Epsilon Sensors can be replaced as required without recalibration (see replacement accuracy)				

^[1] RMS noise referred to the end of the measuring range and to the nominal measuring range, using the standard cable CCg (2.0 m); valid for operation with the DT6530: static 2 Hz, dynamic 8.5 kHz

^[2] Typical linearity to be added to the controller linearity; valid for standard cable adjustment CCg (2.0 m)

^[3] FSO = Full Scale Output | The value corresponds to the slope error that occurs when a sensor is replaced without recalibration

^[4] In relation to the nominal measuring range

Mounting of CSG gap sensors for two-sided measurements

Gap sensors for two-sided measurements are mounted outside the gap to be measured using screws. The flexible part of the sensor extends freely into the gap. Gap sensors for two-sided measurements can also be used in combination with the MD6-22 mobile controller for mobile gap measurement. For this purpose, the sensor is not mounted but is inserted into the measuring gap by hand.

Recommended mounting of CSF sensors

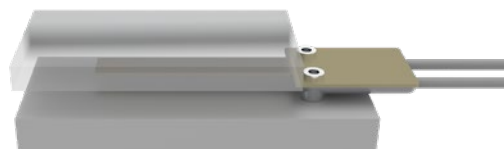

Gap sensors for one-sided measurements

capaNCDT CSF

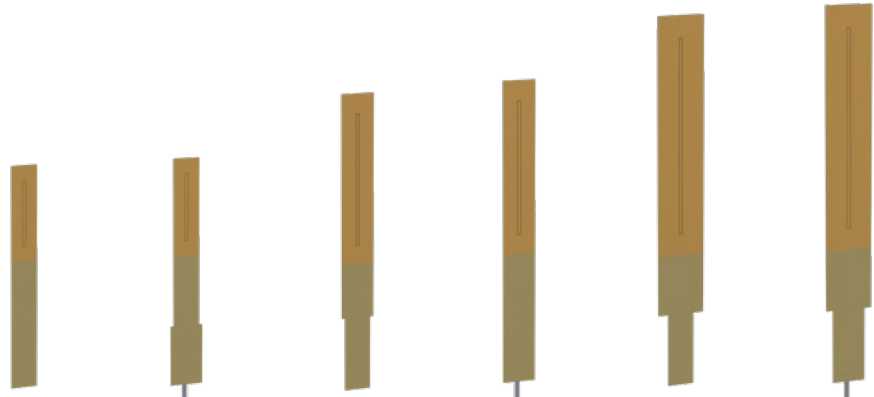

Model		CSF2	CSF2-CRg4.0	CSF4	CSF4-CRg4.0	CSF6	CSF6-CRg4.0
Measuring range	Reduced	1 mm		2 mm		3 mm	
	Nominal	2 mm		4 mm		6 mm	
	Extended	4 mm		8 mm		12 mm	
Resolution ^[1]	Static	0.6 nm		1.2 nm		1.8 nm	
	Dynamic	40 nm		80 nm		120 nm	
Linearity ^[2]		< ±4 μm		< ±8 μm		< ±12 μm	
Replaceability ^[3]		< ±1.5 % FSO		< ±1.0 % FSO		< ±1.0 % FSO	
Temperature stability		-0.2 μm/K		-0.5 μm/K		-0.9 μm/K	
Required gap width		≥ 0.75 mm					
Recommended target size (flat) ^[4]		approx. 50 x 13 mm		approx. 90 x 16.5 mm		approx. 128 x 25 mm	
Active measuring area		35 x 1.5 mm		70 x 1.5 mm		105 x 1.5 mm	
Connection ^[5]		triaxial socket (type E)	integrated cable with connector (type B), length 4 m	triaxial socket (type E)	integrated cable with connector (type B), length 4 m	triaxial socket (type E)	integrated cable with connector (type B), length 4 m
Mounting		Bonding to the underside of the sensor (optionally available with magnetic foil on the underside)					
Temperature range	Storage	-40 ... 100 °C					
	Operation	-40 ... 100 °C					
Shock (DIN EN 60068-2-27)		30g / 5 ms in XY axis, 1000 shocks each					
Vibration (DIN EN 60068-2-6)		20 g / 58 ... 2000 Hz in XY axis, 10 cycles each					
Protection class (DIN EN 60529)		IP40					
Material		Hard tissue GRP / copper / gold					
Weight		approx. 5 g	approx. 75 g (incl. cable)	approx. 7 g	approx. 77 g (incl. cable)	approx. 10 g	approx. 80 g (incl. cable)
Compatibility		Compatible with all capacitive controllers from Micro-Epsilon Sensors can be replaced as required without recalibration (see replacement accuracy)					

^[1] RMS noise referred to the end of the measuring range and to the nominal measuring range, using the standard cable CCg (4.0 m); valid for operation with the DT6530: static 2 Hz, dynamic 8.5 kHz
^[2] Typical linearity to be added to the controller linearity; valid for standard cable adjustment CCg (4.0 m)
^[3] FSO = Full Scale Output | The value corresponds to the slope error that occurs when a sensor is replaced without recalibration
^[4] In relation to the nominal measuring range
^[5] For suitable sensor cables, please refer to Connections

Mounting of CSF gap sensors for one-sided measurements

The gap sensors are attached by bonding them directly into the gap to be measured. CSF-type gap sensors are available with a magnetic strip on the back, allowing them to be quickly attached to metal gaps and removed without leaving any residue (recommended only for mobile measurements, not for continuous use).

Recommended mounting of CSF sensors



Dimensions

capaNCDT CSG/CSF

CSG0,50-CAm2,0

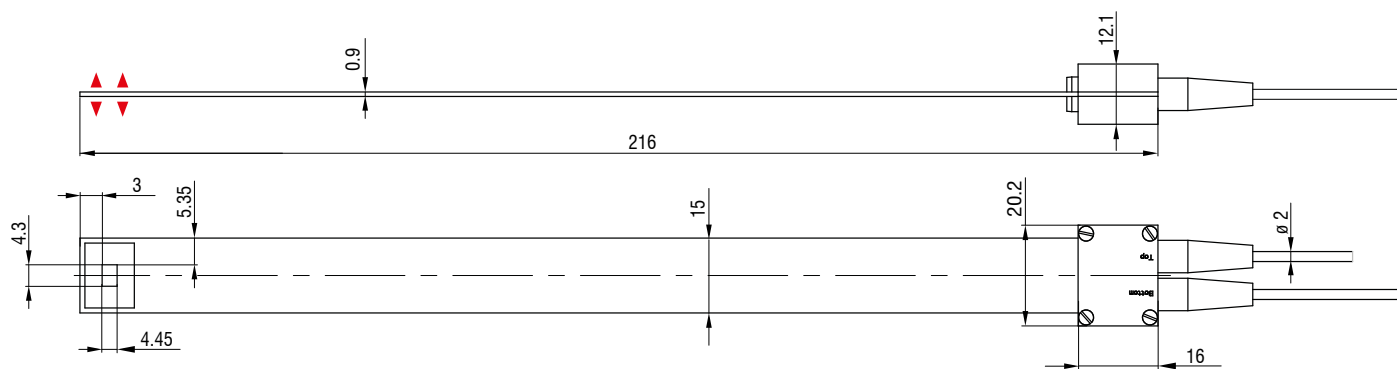

CSG1,00-CAm2,0

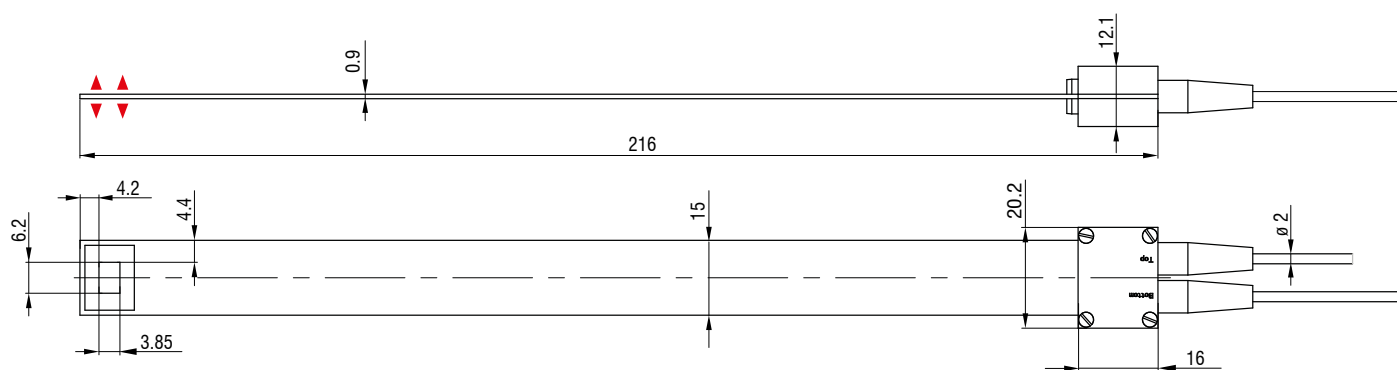

CSG-0.5/CRg2.0

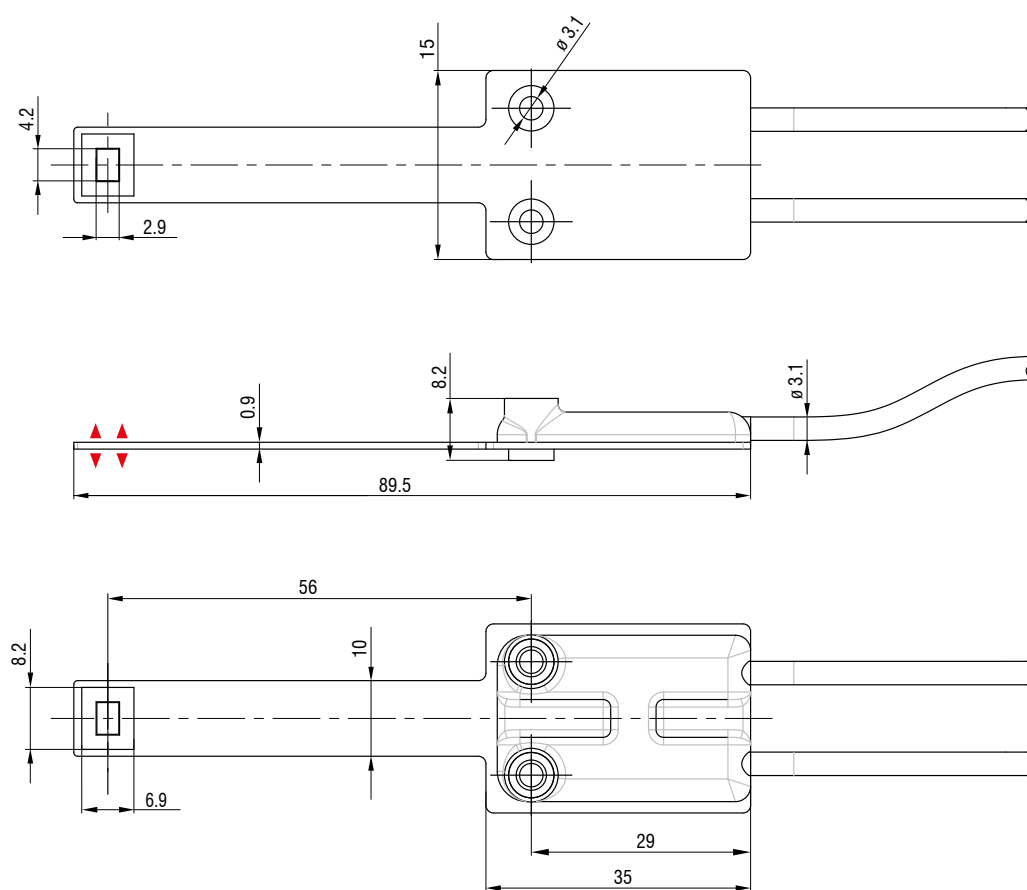

CSG-1/CRg2.0

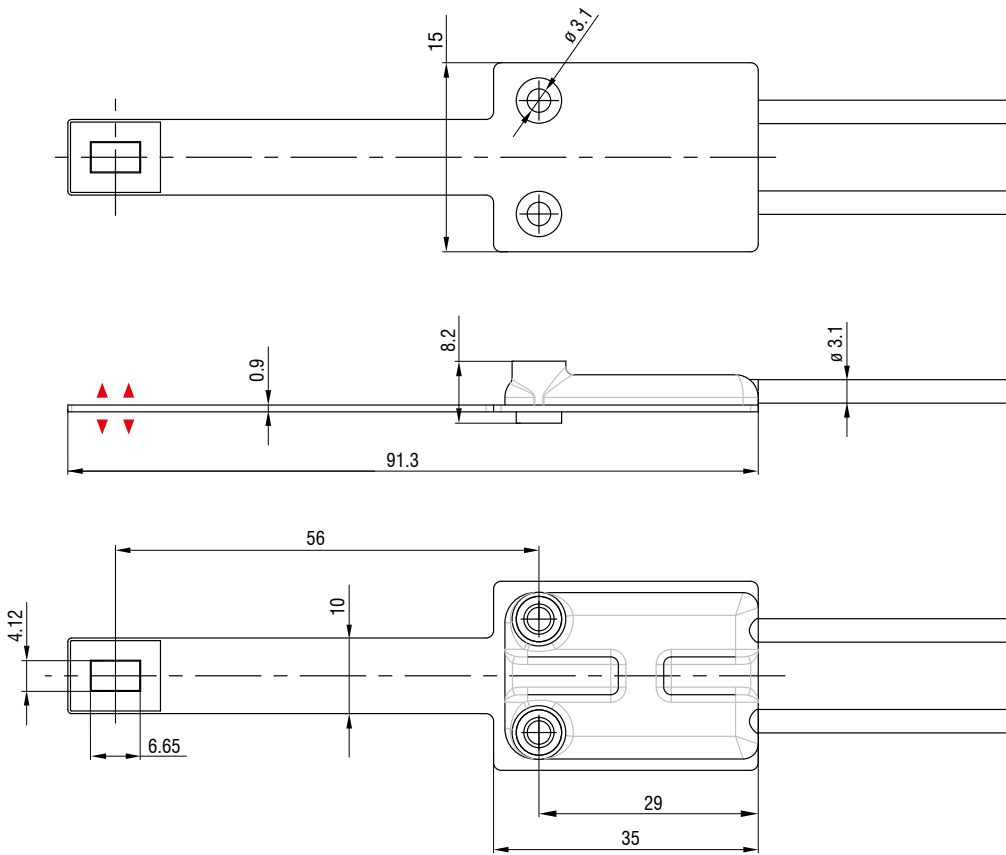

CSG-1/90/CRg2.0

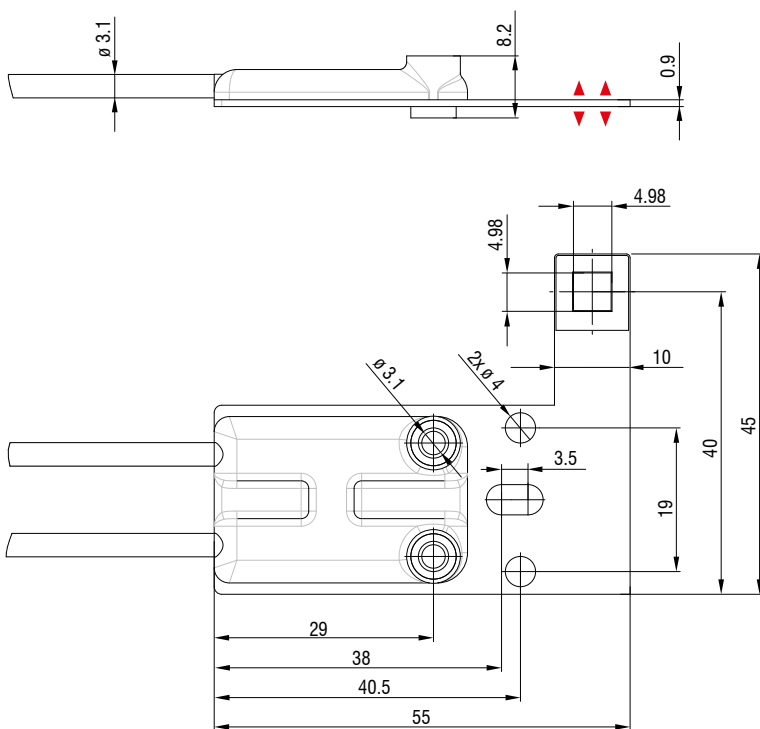

An optional air-purge collar is available for the CSG-0.5/CRg2.0 and CSG-1/CRg2.0 capacitive gap sensors (see Accessories).

▲ ▲ Measurement direction

(dimensions in mm, not to scale)

Dimensions

capa^{NC}DT CSF

Flat sensors with integrated sensor cable

CSF2-CRg4.0

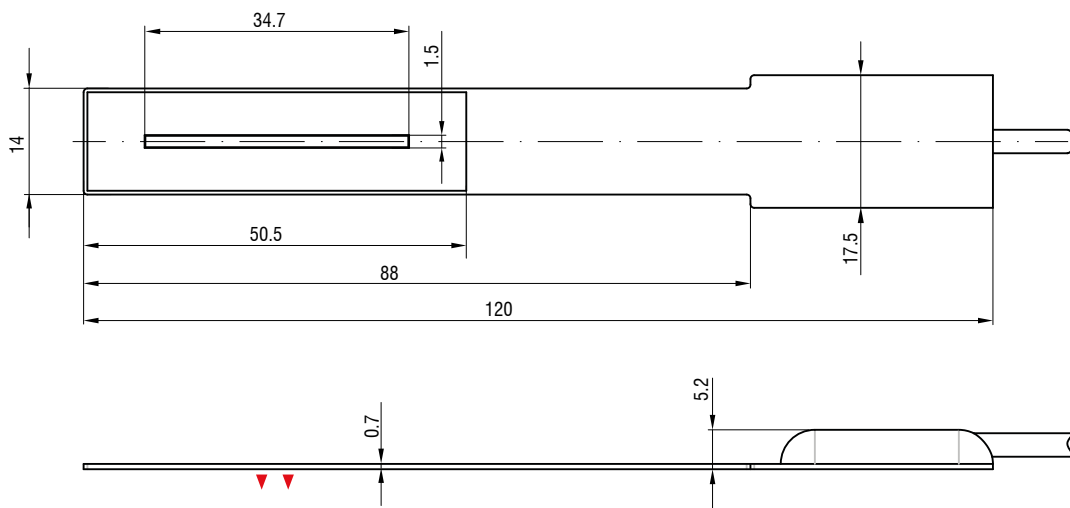

CSF4-CRg4.0

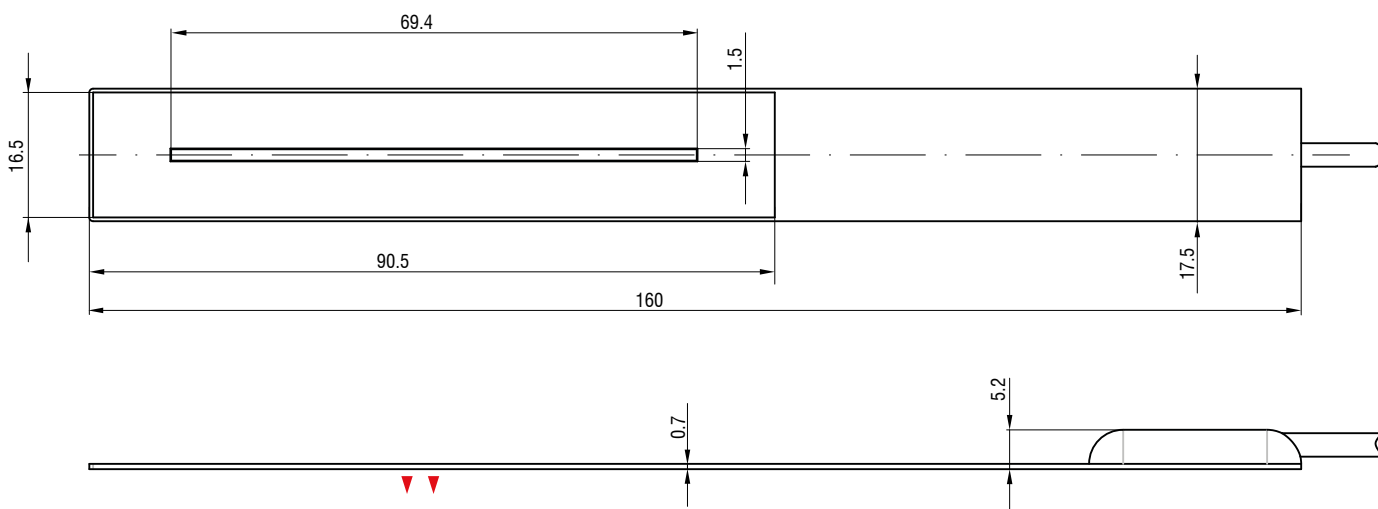

CSF6-CRg4.0

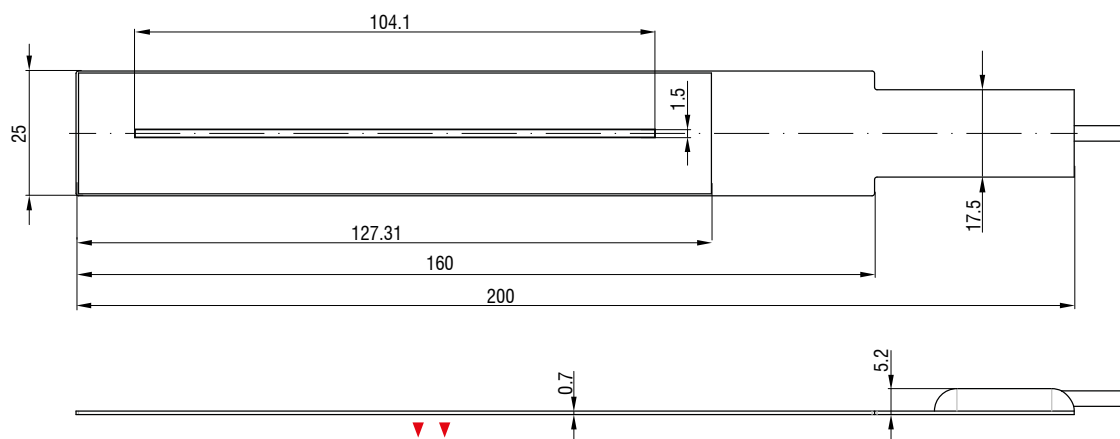

Flat sensors without integrated sensor cable

CSF2

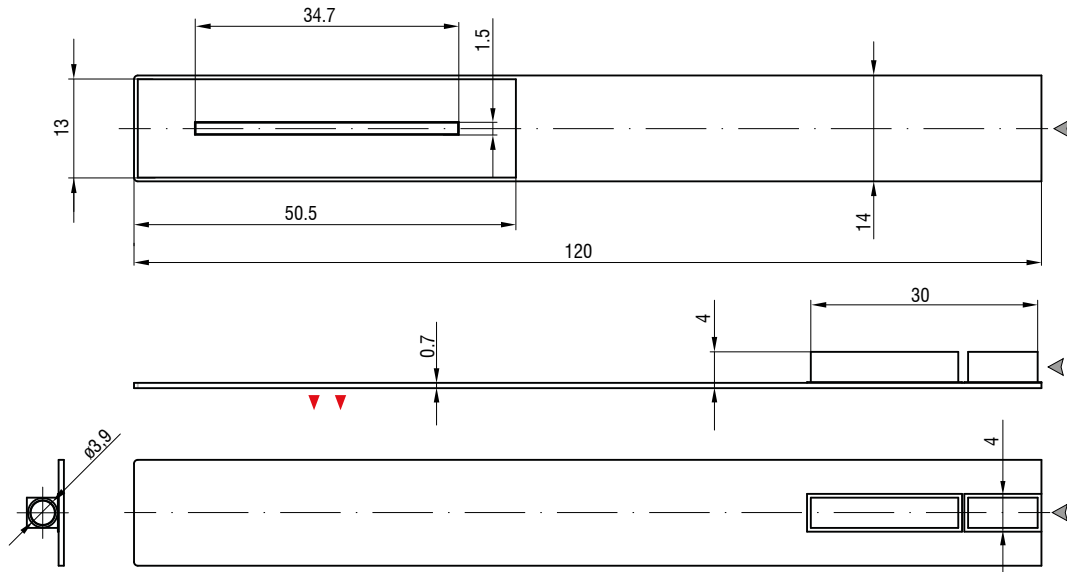

CSF4

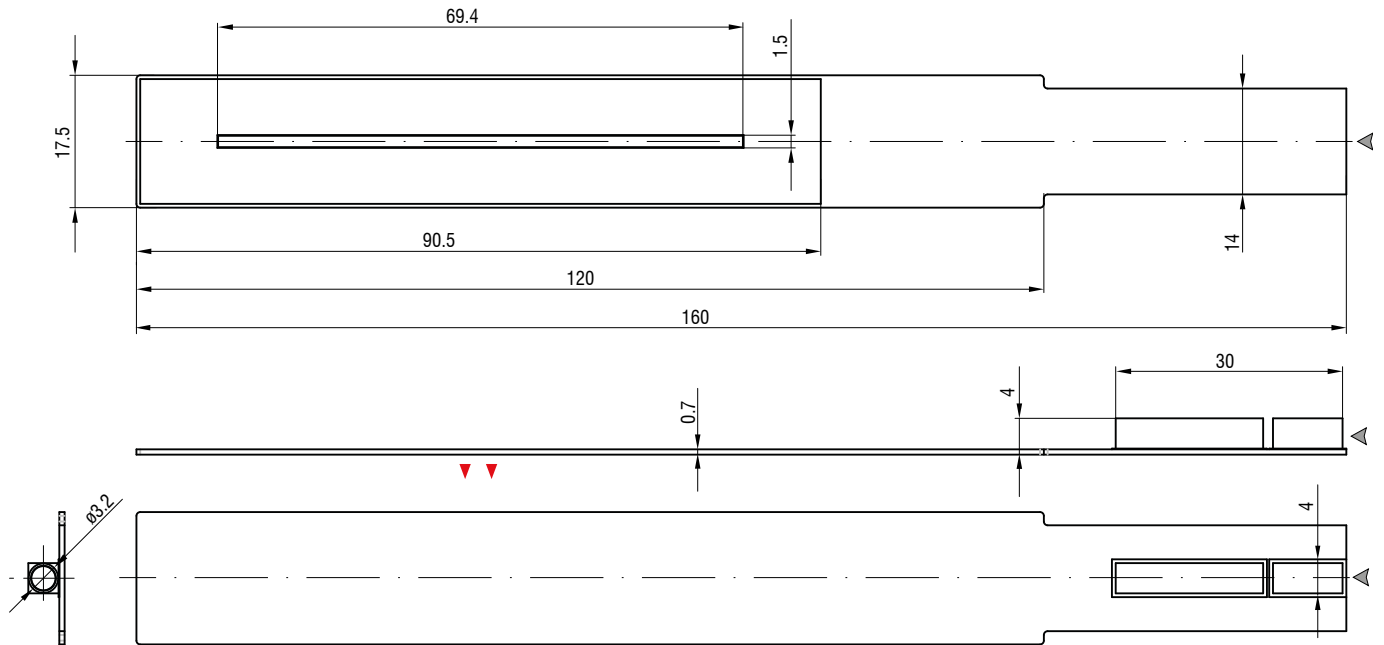

CSF6

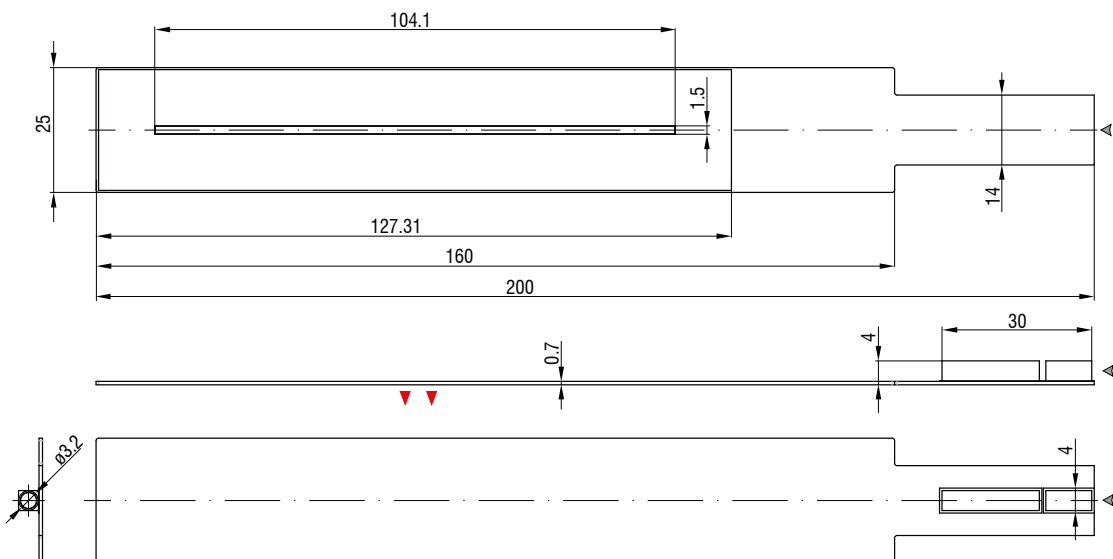

▲ ▲ Measurement direction

▲ Connector side

(dimensions in mm, not to scale)

Sensors for challenging environments

capaNCDT CSE/HT

High-temperature sensors for environments up to +800 °C

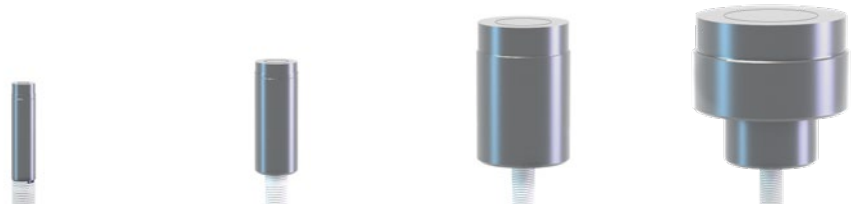

Model		CSE-1/HT/CA-1,0	CSE-2/HT/CA-1,0	CSE-5/HT/CA-1,0	CSE-10/HT/CA-1,0
Measuring range	Reduced	0.5 mm	1 mm	2.5 mm	5 mm
	Nominal	1 mm	2 mm	5 mm	10 mm
	Extended	2 mm	4 mm	10 mm	20 mm
Resolution ^[1]	Static	10 nm	20 nm	50 nm	100 nm
	Dynamic	80 nm	160 nm	400 nm	800 nm
Linearity ^[2]		< ±0.5 μm	< ±1.0 μm	< ±3.5 μm	< ±7 μm
Replaceability ^[3]		< ±5 % FSO	< ±5 % FSO	< ±5 % FSO	< ±5 % FSO
Temperature stability		-0.2 μm / K	-0.4 μm / K	-1.0 μm / K	-2.0 μm / K
Recommended target size (flat) ^[4]		Ø 8 mm	Ø 14 mm	Ø 30 mm	Ø 50 mm
Active measuring area		Ø 5.7 mm	Ø 8.1 mm	Ø 12.9 mm	Ø 18.2 mm
Connection		integrated cable with socket (type B); standard length 1.0 m			
Mounting		Circumferential clamping			
Temperature range	Storage	-50 ... 200 °C			
	Operation	Sensor with cable -50 ... 800 °C / connector -50 ... 200 °C			
Shock (DIN EN 60068-2-27)		20 g / 5 ms in XY axis, 1000 shocks each			
Vibration (DIN EN 60068-2-6)		10 g / 10 ... 2000 Hz in XY axis, 20 cycles each			
Protection class (DIN EN 60529)		IP40			
Material		Inconel Alloy 625			
Weight		approx. 62 g (incl. cable)	approx. 83 g (incl. cable)	approx. 225 g (incl. cable)	approx. 470 g (incl. cable)
Recommended mounting position ^[5]		4.75 mm	4.65 mm	9.10 mm	30 mm
Compatibility		Recommended for use with the capaNCDT 6228 controller from Micro-Epsilon			

^[1] RMS noise related to the end of the measuring range and to the nominal measuring range, using the standard cable CCm (1.4m) and the integrated HT cable (1 m); valid for operation with the DT6530: static 2 Hz, dynamic 8.5 kHz

^[2] Typical linearity to be added to the controller linearity; valid for standard cable adjustment CCm (1.4 m) and integrated HT cable (1 m)

^[3] FSO = Full Scale Output | The value corresponds to the slope error that occurs when a sensor is replaced without recalibration

^[4] In relation to the nominal measuring range

^[5] From the sensor front face (measuring surface), opposite to the measuring direction

Mounting of cylindrical CSE/HT sensors

CSE/HT cylindrical sensors can be installed either protruding (with the sensor extending beyond the mounting bracket) or flush with the mounting bracket. The sensors are mounted by circumferential clamping using a collet. Please note that the surrounding material may cause heat to build up.

Recommended mounting of CSE/HT sensors



Sensors for challenging environments

capaNCDT CSH/SE

Cylindrical sensors for vacuum, cleanroom and strong magnetic fields



Model		CSH-0,25/SE/CAM-1,4	CSH-0,5/SE/CAM-1,4	CSH-1/SE/CAM-1,4	CSH-1,2/SE/CAM-1,4	CSH-2/SE/CAM-1,4
Measuring range	Reduced	0.125 mm	0.25 mm	0.5 mm	0.6 mm	1 mm
	Nominal	0.25 mm	0.5 mm	1 mm	1.2 mm	2 mm
	Extended	0.5 mm	1 mm	2 mm	2.4 mm	4 mm
Resolution ^[1]	Static	0.075 nm	0.15 nm	0.3 nm	0.36 nm	0.6 nm
	Dynamic	5 nm	10 nm	20 nm	24 nm	40 nm
Linearity ^[2]		< ±0.25 μm	< ±0.35 μm	< ±0.6 μm	< ±1.2 μm	< ±0.6 μm
Replaceability ^[3]		< ±0.4 % FSO	< ±0.3 % FSO	< ±0.2 % FSO	< ±0.2 % FSO	< ±0.2 % FSO
Temperature stability ^[4]		-0.04 μm/K	-0.05 μm/K	-0.06 μm/K	-0.05 μm/K	-0.04 μm/K
Recommended target size (flat) ^[5]		Ø 5 mm	Ø 7 mm	Ø 11 mm	Ø 11 mm	Ø 17 mm
Active measuring area		Ø 2.9 mm	Ø 4.1 mm	Ø 5.7 mm	Ø 6.3 mm	Ø 8.1 mm
Connection	integrated cable with connector (type B); standard length 1.4 m					
Mounting	Circumferential clamping					
Temperature range	Storage	-269 ... 200 °C				
	Operation	-269 ... 200 °C				
Shock (DIN EN 60068-2-27)	30g / 5 ms in XY axis, 1000 shocks each					
Vibration (DIN EN 60068-2-6)	20 g / 10 ... 2000 Hz in XY axis, 10 cycles each					
Protection class (DIN EN 60529)	IP40					
Material	3.7035 (Grade 2 titanium)					
Weight		approx. 30 g (incl. cable)	approx. 30 g (incl. cable)	approx. 33 g (incl. cable)	approx. 33 g (incl. cable)	approx. 38 g (incl. cable)
Recommended mounting position ^[6]	3 mm					
Compatibility	Compatible with all capacitive controllers from Micro-Epsilon Sensors can be replaced as required without recalibration (see replacement accuracy)					

^[1] RMS noise referred to the end of the measuring range and to the nominal measuring range using the standard cable CCm (1.4 m); valid for operation with the DT6530: static 2 Hz, dynamic 8.5 kHz

^[2] Typical linearity to be added to the controller linearity; valid for standard cable adjustment CCm (1.4 m)

^[3] FSO = Full Scale Output | The value corresponds to the slope error that occurs when a sensor is replaced without recalibration

^[4] In the recommended mounting position

^[5] In relation to the nominal measuring range

^[6] From the sensor front face (measuring surface), opposite to the measuring direction

Mounting of cylindrical CSH/SE sensors

CSH/SE cylindrical sensors can be installed either protruding (with the sensor extending beyond the mounting bracket) or flush with the mounting bracket. The sensor is mounted either by point clamping using a plastic set screw or by circumferential clamping using a collet. When using circumferential clamps, please note that the surrounding material may cause heat buildup.

Recommended mounting of CSH/SE sensors



With set screw

With circumferential clamping

Sensors for challenging environments

capaNCDT CSH/FL/SE

Flat sensors for vacuum, cleanroom and strong magnetic fields

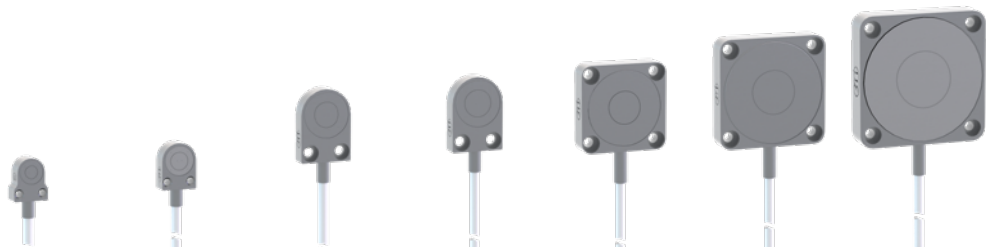

Model		CSH-0,25/FL/SE/CRm-1,4	CSH-0,5/FL/SE/CRm-1,4	CSH-1/FL/SE/CRm-1,4	CSH-1,2/FL/SE/CRm-1,4	CSH-2/FL/SE/CRm-1,4	CSH-3/FL/SE/CRm-1,4	CSH-5/FL/SE/CRm-1,4
Measuring range	Reduced	0.125 mm	0.25 mm	0.5 mm	0.6 mm	1 mm	1.5 mm	2.5 mm
	Nominal	0.25 mm	0.5 mm	1 mm	1.2 mm	2 mm	3 mm	5 mm
	Extended	0.5 mm	1 mm	2 mm	2.4 mm	4 mm	6 mm	10 mm
Resolution ^[1]	Static	0.075 nm	0.15 nm	0.3 nm	0.36 μm	0.6 nm	0.9 nm	1.5 nm
	Dynamic	5 nm	10 nm	20 nm	24 μm	40 nm	60 nm	100 nm
Linearity ^[2]		< ±0.25 μm	< ±0.35 μm	< ±0.6 μm	< ±1.2 μm	< ±0.6 μm	< ±1.5 μm	< ±15 μm
Replaceability ^[3]		< ±0.4 % FSO	< ±0.3 % FSO	< ±0.2 % FSO	< ±0.2 % FSO	< ±0.2 % FSO	< ±0.2 % FSO	< ±0.5 % FSO
Temperature stability	Front-side mounting	+0.025 μm/K	+0.015 μm/K	+0.035 μm/K	+0.042 μm/K	+0.08 μm/K	+0.075 μm/K	+0.1 μm/K
	Rear-side mounting	-0.011 μm/K	-0.021 μm/K	-0.001 μm/K	+0.006 μm/K	+0.035 μm/K	+0.03 μm/K	+0.055 μm/K
Recommended target size (flat) ^[4]		Ø 5 mm	Ø 7 mm	Ø 11 mm	Ø 11 mm	Ø 17 mm	Ø 24 mm	Ø 30 mm
Active measuring area		Ø 2.9 mm	Ø 4.1 mm	Ø 5.7 mm	Ø 6.3 mm	Ø 8.1 mm	Ø 10 mm	Ø 13 mm
Connection		integrated cable with connector (type B); standard length 1.4 m						
Mounting		2 x M2 thread		2 x through hole for M2 screw		4 x through hole for M2 screw		
Temperature range	Storage	-269 ... 200 °C						
	Operation	-269 ... 200 °C						
Shock (DIN EN 60068-2-27)		30g / 5 ms in XY axis, 1000 shocks each						
Vibration (DIN EN 60068-2-6)		20 g / 58 ... 2000 Hz in XY axis, 10 cycles each						
Protection class (DIN EN 60529)		IP40						
Material		3.7035 (Grade 2 titanium)						
Weight		approx. 28 g (incl. cable)	approx. 28 g (incl. cable)	approx. 30 g (incl. cable)	approx. 30 g (incl. cable)	approx. 37 g (incl. cable)	approx. 37 g (incl. cable)	approx. 37 g (incl. cable)
Compatibility		Compatible with all capacitive controllers from Micro-Epsilon Sensors can be replaced as required without recalibration (see replacement accuracy)						

^[1] RMS noise referred to the end of the measuring range and to the nominal measuring range using the standard cable CCm (1.4 m); valid for operation with the DT6530: static 2 Hz, dynamic 8.5 kHz

^[2] Typical linearity to be added to the controller linearity; valid for standard cable adjustment CCm (1.4 m)

^[3] FSO = Full Scale Output | The value corresponds to the slope error that occurs when a sensor is replaced without recalibration

^[4] In relation to the nominal measuring range

Mounting of CSH/FL/SE flat sensors

The flat sensors are mounted using a threaded hole for M2 screws (for the CSH-0.25/FL/SE and CSH-0.5/FL/SE sensors) or a through hole for M2 screws. The sensors can be screwed on from above or below.

Recommended mounting of CSH/FL/SE sensors



Top screw connection on the sensor base



Screw mounting from below on the top of the sensor (CSH-0.25FL – CSH-1.2/FL/SE)

Dimensions

capaNCDT CSE/HT / capaNCDT CSH/SE

CSE/HT

CSE-1/HT/CA-1,0

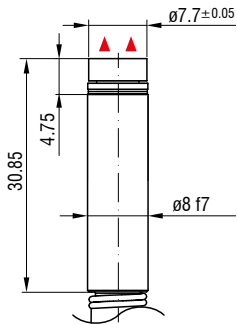

CSE-2/HT/CA-1,0

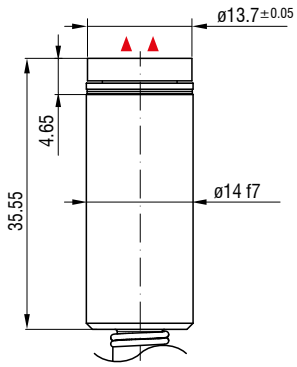

CSE-5/HT/CA-1.0

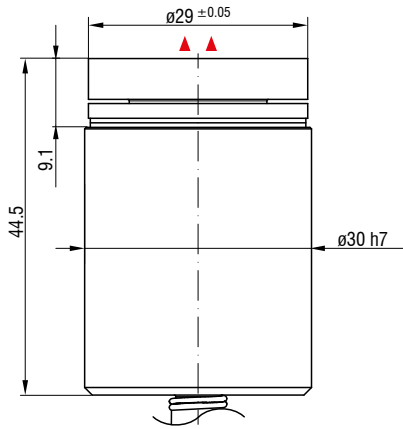

CSE-10/HT/CA-1,0

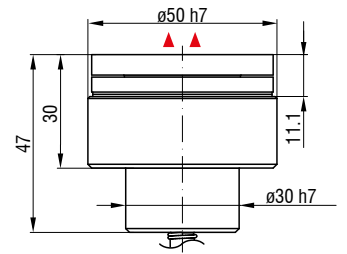

CSH/SE

CSH-0,25/SE/CAm-1,4

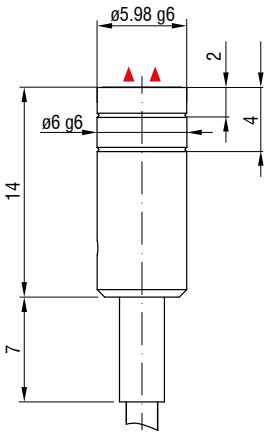

CSH-0,5/SE/CAm-1,4

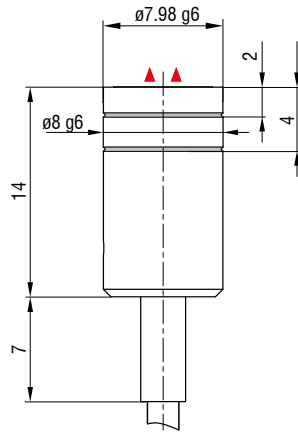

CSH-1/SE/CAm-1,4

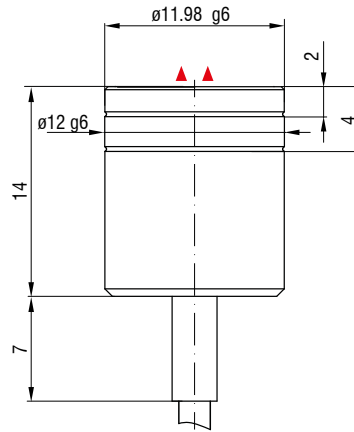

CSH-1,2/SE/CAm-1,4

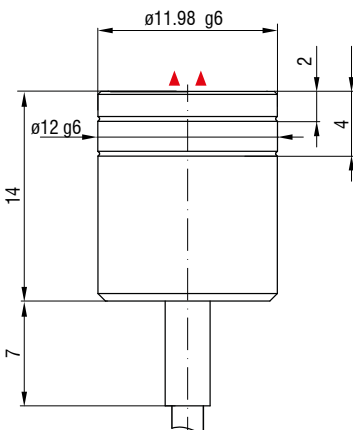

CSH-2/SE/CAm-1,4

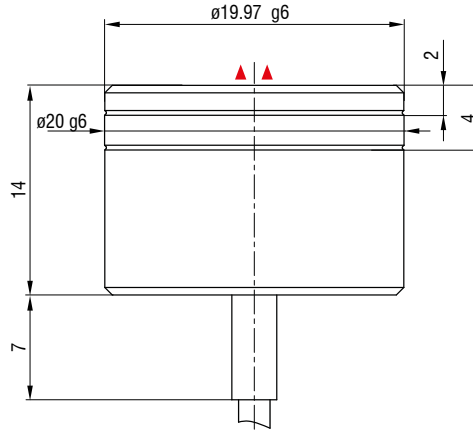

CSH/FL/SE

CSH-0,25/FL/SE/
 CRm-1,4

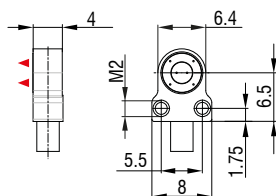

CSH-0,5/FL/SE/
 CRm-1,4

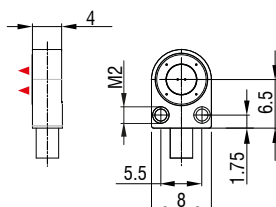

CSH-1/FL/SE/
 CRm-1,4

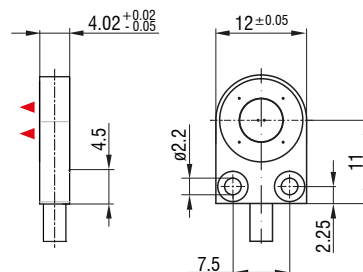

CSH-1,2/FL/SE/
 CRm-1,4

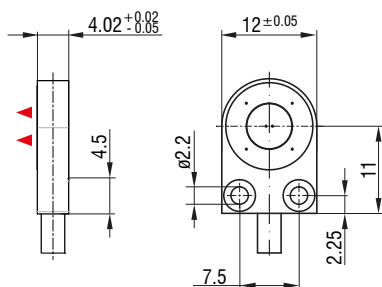

CSH-2/FL/SE/
 CRm-1,4

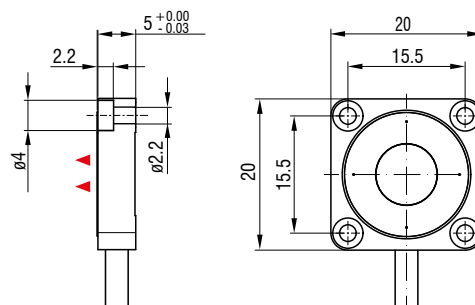

CSH-3/FL/SE/
 CRm-1,4

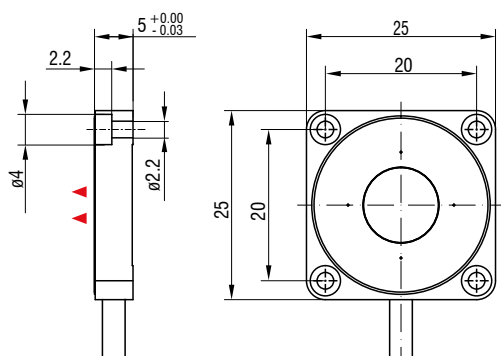

CSH-5/FL/SE/
 CRm-1,4

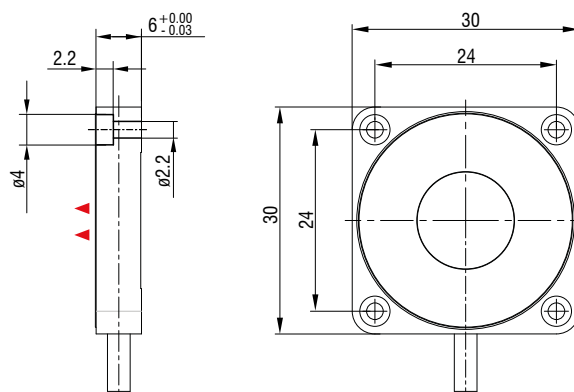

Dimensions of the connectors

capaNCDT

All sensors can be combined with all controllers and sensor cables. To connect the sensors, you simply need to use the correct type of connector. Micro-Epsilon will select the right sensor cable with the appropriate connectors for you during the quotation and ordering process. The following dimensional drawings are intended to help you make an initial selection.

- The sensor connection varies depending on the sensor type. Depending on the model, the cable is either permanently integrated into the sensor or connected via an external sensor cable. Depending on the design and size, different connector types and sizes are used, which must be taken into account when selecting sensor cables. For more information on this, please refer to the technical specifications for the sensors under "Connection".
- The sensor is always connected to the controller using a type B connector.

You can find an overview of all connection and combination options on pages 52 - 53.

Type B connector

- On each sensor with an integrated cable or on one end of a sensor cable (except CSE/HT)
- For plug-in sensors with measuring ranges of ≥ 1 mm

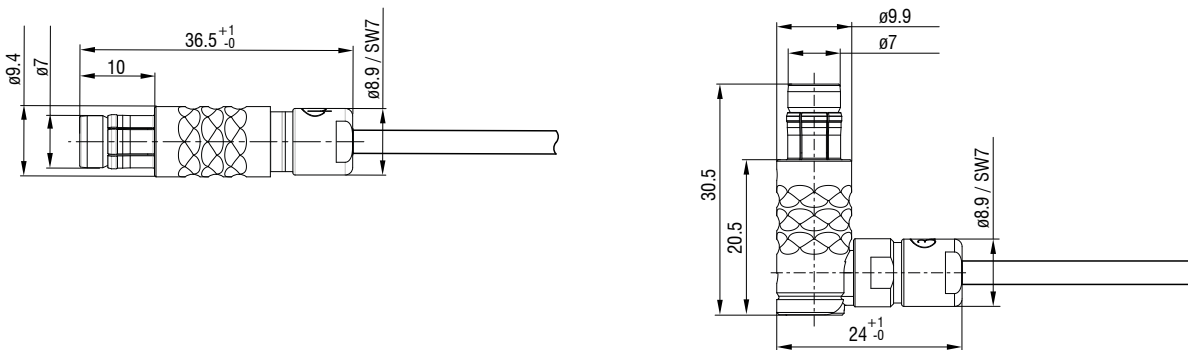

Cable with connector type C

- On one end of a sensor cable
- For all plug-in sensors with measuring ranges of ≤ 1 mm

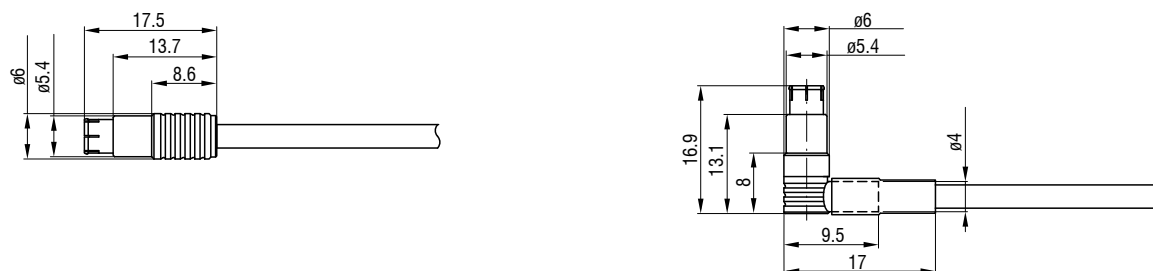

Cable with connector type E

- On one end of a sensor cable
- For all CSF flat sensors

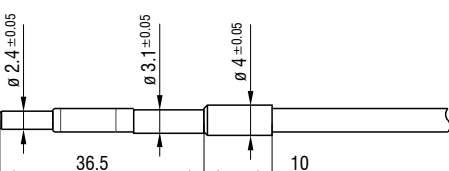

Capacitive controllers

Modern, powerful, flexible



Superior controller technology

Micro-Epsilon's capaNCdT controllers set the standard for performance, signal conditioning, and signal processing. In addition, they are easy to use and, due to the extensive product portfolio, can be adapted to virtually any application.

Integration via modern interfaces

Ethernet
RS485
Analog

EtherNet/IP
 
 EtherCAT

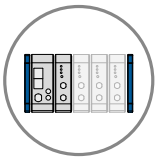

Multi-channel controller

- Up to 8 measuring channels
- Mathematical functions for signal processing
- For economical solutions

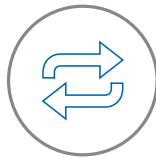

Synchronizable

- For precise and synchronous measurements:
- Internal synchronization between all sensors on one controller
 - External synchronization between several controllers
 - Virtual grounding possible

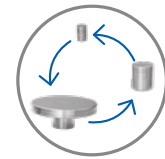

Easy replacement of sensors and controller

- Plug & Play for sensors and controller
- No calibration or linearization required
- Highest precision after sensor replacement (see specifications for "replacement accuracy")

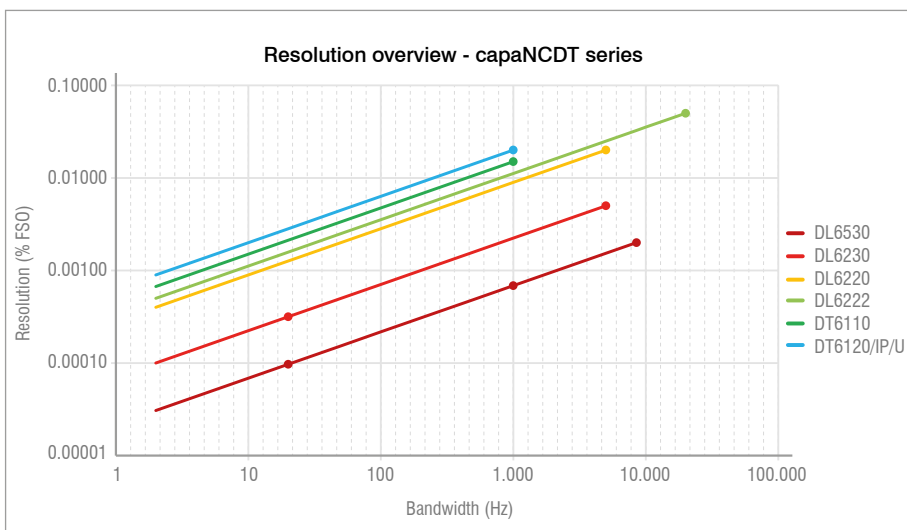

Depending on the system configuration, a specific resolution and system accuracy are achieved. The figure on the right can help you choose the right controller. Please contact our sales team for exact specifications.

Simple operation via web interface

The capaNCDT web interface is accessed via a web browser. It offers a user-friendly interface for parameter configuration, data processing, and signal display. Setups can be saved, loaded and transferred to other controllers. Up to 8 channels can be displayed and linked arithmetically.

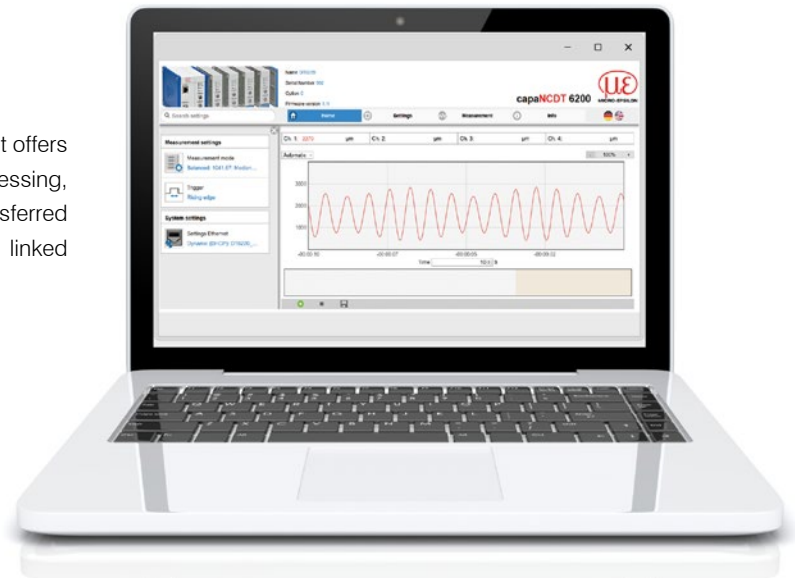

Custom-designed for your application

The capaNCDT controllers offer a wide range of optional adjustments and special calibrations. This makes it possible, for example, to use longer cables, expand or reduce the measuring range, or achieve even higher levels of accuracy.

Extended sensor cable

When extending the sensor cable, the standard length is multiplied by the extension factor. Standard lengths are 1 m (CC), 1.4 m (CCm), and 2 m (CCg, CCr, and CCo), depending on the cable type. The maximum cable length is therefore 8 m. An exception is the DT6114 system (page 62), which is specifically designed for very long sensor cables of up to 15 m.

For details on the sensor cables and connection options, see pages 52 - 53.

Modified measuring range

By narrowing or extending the measuring range, it is possible, for example, to increase the resolution or extend the measuring range without having to select a different sensor model.

In this case, the measuring range is multiplied by a factor. The sensor tables provide values for factors of 0.5 (reduced) and 2 (extended).

Linearity calibration







Linearity calibration improves the linearity of the entire system by a factor of about 10 by calibrating the controller, sensor cable, and sensor to each other. To maintain the improved linearity, the controller must be recalibrated when the sensor is replaced.

Example: The linearity of a CSE2 sensor with a DT6120/IP/I controller and a CCg6B/PT cable improves from 0.3 % (6 μ m) to 0.02 % FSO (0.4 μ m) through linearity calibration.

Controller			Extended sensor cable			Modified measuring range			Linearity calibration
Basic module	Demodulator	Preamplifier	2x	3x	x	0.5x	2x	x	
DT6530	DL6530		✓	✓	-	✓	✓	✓	Included
	DL6510	CPM6011	✓	✓	-	✓	✓	✓	Included
	DL6510	CP6001	✓	✓	-	✓	✓	✓	Included
DT6220	DL6230		✓	✓	-	✓	✓	✓	✓
DT6230	DL6220		✓	✓	-	✓	✓	-	✓
DT6240			✓	-	-	✓	✓	-	✓
DT6222	DL6222		✓	-	-	✓	✓	-	✓
DT6228	DL6228		✓	✓	✓	✓	✓	✓	Included
DT6238			✓	✓	✓	✓	✓	✓	
DT6110			✓	✓	✓	✓	✓	✓	✓
DT6112			✓	-	-	✓	✓	-	✓
DT6120			✓	✓	✓	✓	✓	✓	✓
DT61xx/IP			✓	✓	✓	✓	✓	✓	✓

✓ Optionally available ✓ Available on request

Compact capacitive measuring system for industrial use (single-channel) **capaNCDT 6100**

-  Compact and robust design
-  High resolution and accuracy in industrial applications
-  **INTER FACE** Analog output (current/voltage) and digital RS485 interface
-  **20kHz** Frequency response up to 20 kHz
-  Large range of models for versatile use
-  **made for OEM** Ideal for OEM applications



The capaNCDT 6100 is an analog, single-channel capacitive system that stands out for its robust design and high performance. Its compact design and ease of integration make it particularly well suited for integration into machinery and systems. The controller offers excellent value for money, particularly for OEM and series production.

This high-performance compact system is available in various models, making it suitable for a wide range of applications. Depending on the application, the focus may be on high speed, digital interfaces, exceptional durability, or long signal transmission paths, for example.

Robust, powerful and versatile – the capaNCDT 6100 controller

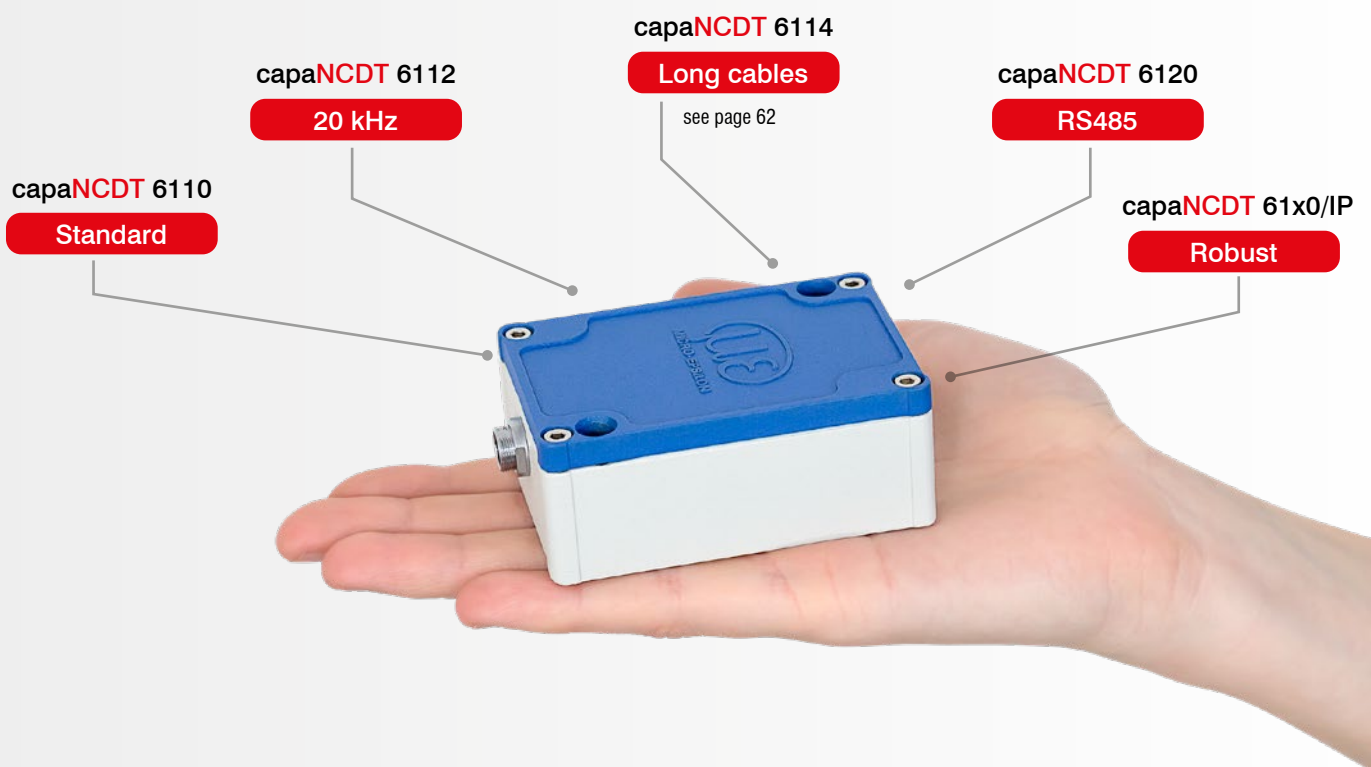

Model		DT6110	DT6112	DT6120	DT6110/IP	DT6120/IP
Resolution ^[1]	Static	0.0007 % FSO	0.0014 % FSO	0.0007 % FSO	0.0009 % FSO	
	Dynamic	0.015 % FSO	0.03 % FSO	0.015 % FSO	0.02 % FSO	
Frequency response (-3dB)		1 kHz	20 kHz	1 kHz	1 kHz	
Measuring rate		-	-	Selectable: max. 2 kSa/s	-	Selectable: max. 2 kSa/s
Linearity ^[2]		< ±0.05% FSO	< ±0.1% FSO	< ±0.05% FSO	< ±0.1% FSO	
Temperature stability		< 200 ppm FSO/K			< 50 ppm FSO/K ^[3]	
Replaceability ^[4]						< ±0.1% FSO
Long-term stability		< ±0.05% FSO/month			< ±0.02% FSO/month	
Synchronization		no				
Supply voltage		9 ... 36 VDC		9 ... 28 VDC	9 ... 28 VDC	
Power consumption		1.32 W (24 VDC)		1.44 W (24 VDC)	1.4 W (voltage) / 2 W (current)	1.6 W (voltage) / 2.2 W (current)
Digital interface ^[5]		-		RS485	-	RS485
Analog output		0 ... 10 V, optional: ±5 V, 10 ... 0 V			0 ... 10 V / ±5 V (short circuit proof) or 4 ... 20 mA (max. burden 500 Ω)	
Connection	Sensor	Pluggable cable via triaxial socket (type B)				
	Supply/ signal	5-pin connector (suitable connection cables, see accessories)		6-pin connector (suitable connection cables, see accessories)		
Mounting		2 x through-bores for M4 screw				
Temperature range	Storage	-10 ... 75 °C			-20 ... 75 °C	
	Operation	10 ... 60 °C			-20 ... 60 °C	
Shock (DIN EN 60068-2-29)		20 g / 5 ms in 3 axes, two directions each, 1000 shocks each				
Vibration (DIN EN 60068-2-6)		1 mm / 10 Hz ... 49.8 Hz in 3 axes, 10 cycles each 10 g / 49.8 ... 2000 Hz in 3 axes, 10 cycles each			2 mm / 10 Hz ... 35 Hz in 3 axes, 10 cycles each 10 g / 35 ... 2000 Hz in 3 axes, 10 cycles each	
Protection class (DIN EN 60529)		IP40			IP68	
Material		die-cast aluminum				
Weight		approx. 190 g				
Compatibility		compatible with all capaNCDT sensors				
No. of measurement channels		1				

^[1] FSO = Full Scale Output | RMS noise referred to the end of the measuring range; static = 2 Hz, dynamic = maximum frequency response of the controller

^[2] Applies to the controller only. The total linearity of the measuring channel is the sum of the controller and sensor values.

^[3] Valid at +10 °C ... +40 °C; 100 ppm FSO / K at -20 °C ... +10 °C and at +40 °C ... +60 °C

^[4] FSO = Full Scale Output | The value corresponds to the slope error that occurs when a sensor is replaced without recalibration

^[5] Baud rate 230400 Bd (adjustable), max. 2 kSa/s (adjustable), 24-bit measurement values

DT6110 / DT6112

Pin assignment for power supply and signal

Pin	Assignment	Color (color SCACx/5)
1	Supply +24 V	White
2	GND supply	Gray
3	Not assigned	Yellow
4	GND analog output	Green
5	Analog output V (load min. 10 kΩ)	Brown

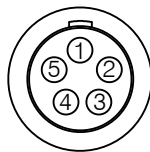

Solder side view,
5-pin socket

DT6120

Pin assignment for power supply and signal

Pin	Assignment	Color (color SCACx/6)
1	Supply +24 V	White
2	GND supply	Gray
3	RS485 A	Pink
4	GND analog output	Green
5	Analog output V (load min. 10 kΩ)	Brown
6	RS485 B	Blue

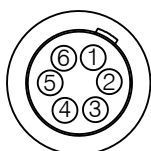

Solder side view,
6-pin socket

DT6110/IP and DT6120/IP





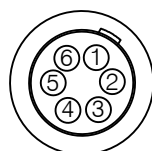

Pin assignment for power supply and signal

Pin	Assignment	Color (cable SCACx/6/IP)
1	Supply +24 V	White
2	GND supply	Gray
3	RS485 A	Pink
4	GND analog output	Green
5	Voltage output (load, min. 10 kΩ) Current output (max. 500 kΩ burden)	Brown
6	RS485 B	Blue



Solder side view,
6-pin socket

Capacitive, high-performance measuring system (up to 4 channels) capaNCDT 6200

-  High resolution down to 0.0001 % FSO
-  **INTER FACE** Analog outputs / Ethernet / EtherCAT / PROFINET interface
-  20kHz Ideal for fast measurements up to 20 kHz
-  Digital data rate: 4 x 3.9 kSa/s
-  Modular system scalable up to 4 channels
-  Supports triggering and synchronization
-  Simple configuration via web interface



The capaNCDT 6200 is a modular measuring system designed for high-precision measurements. It consists of a controller and the corresponding demodulator for the sensor. The modular design allows up to four measurement channels to be combined and flexibly adapted to different measurement tasks.

The Ethernet interface integrated in the controller allows for easy configuration via a web browser. In addition, analog outputs and digital interfaces are available.

The compact controller can be used as a benchtop unit or mounted on a DIN rail or wall using adapters.

The DT6200 is available in various models. Depending on the base module (controller) used and the compatible demodulator, different interfaces are available or higher resolutions can be achieved.

Flexible system design for maximum performance in your application

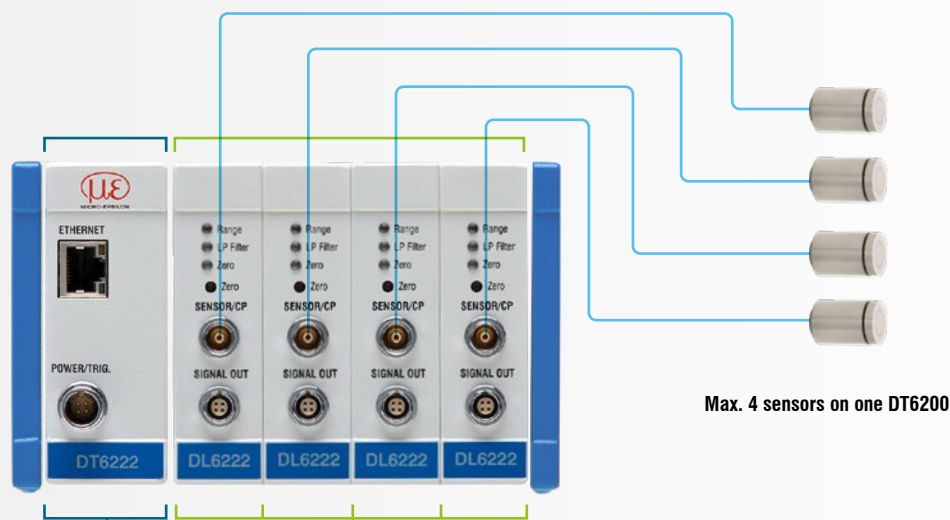

Basic module (controller)
 DT6220: Ethernet
 DT6230: Ethernet / EtherCAT
 DT6240: PROFINET
 DT6222: High speed
 DT6228 / DT6238: for HT sensors

Demodulator with integrated preamplifier
 Depending on the application
 DL6220: Standard
 DL6230: Highest resolution
 DL6222: High speed
 DL6228: For HT sensors

Modular multi-channel system with Ethernet / EtherCAT / PROFINET

Model	DT6220		DT6230		DT6240		
Demodulator	DL6220	DL6230	DL6220	DL6230	DL6220	DL6230	
Resolution ^[1]	Static	0.0004 % FSO	0.0001 % FSO	0.0004 % FSO	0.0001 % FSO	0.0004 % FSO	0.0001 % FSO
	Dynamic	0.02 % FSO	0.005 % FSO	0.02 % FSO	0.005 % FSO	0.02 % FSO	0.005 % FSO
Frequency response (-3dB)	5 kHz, switchable to 20 Hz						
Measuring rate	max. 3.906 kSa/s						
Linearity ^[2]	< ±0.05 % FSO	< ±0.025 % FSO	< ±0.05 % FSO	< ±0.025 % FSO	< ±0.05 % FSO	< ±0.025 % FSO	
Temperature stability	< 200 ppm FSO/K						
Replaceability ^[3]	< ±0.1 % FSO						
Long-term stability	< ±0.02% FSO/month						
Synchronization	yes (only internal)	yes	yes (only internal)	yes	yes (only internal)	yes	
Supply voltage	12 ... 36 VDC	15 ... 36 VDC	12 ... 36 VDC	15 ... 36 VDC	15 ... 36 VDC	15 ... 36 VDC	
Power consumption	3 W (24 VDC) + 1.9 W / demodulator	3 W (24 VDC) + 1.9 W / demodulator	3.9 W (24 VDC) + 1.9 W / demodulator	3.9 W (24 VDC) + 1.9 W / demodulator	3.9 W (24 VDC) + 1.9 W / demodulator	3.9 W (24 VDC) + 1.9 W / demodulator	
Signal input	Trigger: TTL (5 V)						
Digital interface	Ethernet		Ethernet/EtherCAT		PROFINET		
Analog output	0 ... 10 V / 4 ... 20 mA						
Connection	Sensor	Pluggable cable via triaxial socket					
	Supply/signal	Supply/trigger: 4-pin connector; sync: 5-pin connector; signal: analog via 4-pin connector, digital via RJ45 connector (for suitable connection cables, see accessories)					
Mounting	Table-top device or DIN rail						
Temperature range	Storage	-10 ... 75 °C					
	Operation	10 ... 60 °C					
Shock (DIN EN 60068-2-29)	15 g / 6 ms in 3 axes, two directions each, 1000 shocks each						
Vibration (DIN EN 60068-2-6)	0.75 mm / 10 ... 500 Hz in 3 axes, 2 directions and 10 cycles each 2 g / 10 ... 500 Hz in 3 axes, 2 directions and 10 cycles each						
Protection class (DIN EN 60529)	IP40						
Weight	approx. 710 g + 185 g / demodulator	approx. 710 g + 210 g / Demodulator	approx. 720 g + 185 g / demodulator	approx. 720 g + 210 g / demodulator	approx. 720 g + 185 g / demodulator	approx. 720 g + 210 g / demodulator	
Compatibility	compatible with all capaNCdT sensors						
No. of measurement channels	max. 4						

^[1] FSO = Full Scale Output | RMS noise referred to the end of the measuring range; static = 2 Hz, dynamic = maximum frequency response of the controller

^[2] Applies to the controller only. The total linearity of the measuring channel is the sum of the controller and sensor values.

^[3] FSO = Full Scale Output | The value corresponds to the slope error that occurs when a sensor is replaced without recalibration

DT6220 / DT6230 / DT6240

Pin assignment for power supply and trigger

Pin	Assignment	Color (cable PC6200-x/4)
1	Supply +24 V	Brown
2	GND supply	White
3	Trigger IN+, TTL level	Yellow
4	Trigger IN-	Green

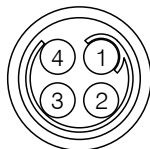

Solder side view,
4-pin socket

DT6220 / DT6230 / DT6240

Pin assignment for analog output

Pin	Assignment	Color (color SCACx/4)
1	U _{OUT} (load min. 10 kOhm)	Brown
2	I _{OUT} (burden max. 500 ohm)	Yellow
3	Analog ground	Gray
4	Analog ground	White

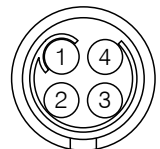

Solder side view,
4-pin cable
connector

Capacitive, high-performance measuring system (up to 4 channels)

capaNCDT 6200

Modular multi-channel system for high-speed measurements

Model		DT6222
Demodulator		DL6222
Resolution ^[1]	Static	0.0005 % FSO
	Dynamic	0.05 % FSO
Frequency response (-3dB)		20 kHz, switchable to 20 Hz
Measuring rate		max. 3.906 kSa/s
Linearity ^[2]		< ±0.1 % FSO
Temperature stability		< 200 ppm FSO/K
Replaceability ^[3]		< ±0.1 % FSO
Long-term stability		< ±0.02% FSO/month
Synchronization		yes (only internal)
Supply voltage		12 ... 36 VDC
Power consumption		2.8 W (24 VDC) + 1.2 W / demodulator
Signal input		Trigger: TTL (5 V)
Digital interface		Ethernet
Analog output		0 ... 10 V / 4 ... 20 mA
Connection	Sensor	Pluggable cable via triaxial socket
	Supply/signal	Supply/trigger: 4-pin connector; sync: 5-pin connector; signal: analog via 4-pin connector, digital via RJ45 connector (for suitable connection cables, see accessories)
Mounting		Table-top device or DIN rail
Temperature range	Storage	-10 ... 75 °C
	Operation	10 ... 60 °C
Shock (DIN EN 60068-2-29)		15 g / 6 ms in 3 axes, two directions each, 1000 shocks each
Vibration (DIN EN 60068-2-6)		0.75 mm / 10 ... 500 Hz in 3 axes, 2 directions and 10 cycles each 2 g / 10 ... 500 Hz in 3 axes, 2 directions and 10 cycles each
Protection class (DIN EN 60529)		IP40
Weight		approx. 710 g + 185 g / demodulator
Compatibility		compatible with all capaNCDT sensors
No. of measurement channels		max. 4

^[1] FSO = Full Scale Output | RMS noise referred to the end of the measuring range; static = 2 Hz, dynamic = maximum frequency response of the controller

^[2] Applies to the controller only. The total linearity of the measuring channel is the sum of the controller and sensor values.

^[3] FSO = Full Scale Output | The value corresponds to the slope error that occurs when a sensor is replaced without recalibration

DT6222

Pin assignment for power supply and trigger

Pin	Assignment	Color (cable PC6200-x/4)
1	Supply +24 V	Brown
2	GND supply	White
3	Trigger IN+, TTL level	Yellow
4	Trigger IN-	Green

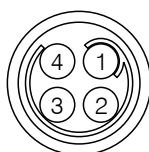

Solder side view,
4-pin socket

DT6222

Pin assignment for analog output

Pin	Assignment	Color (color SCACx/4)
1	U _{OUT} (load min. 10 kOhm)	Brown
2	I _{OUT} (burden max. 500 ohm)	Yellow
3	Analog ground	Gray
4	Analog ground	White

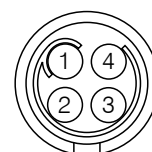

Solder side view,
4-pin cable
connector

Modular multi-channel system for high-temperature sensors

Model	DT6228		DT6238
Demodulator	Demodulator DL6228		
Resolution ^[1]	Static	0.0005 % FSO	
	Dynamic	0.01 % FSO	
Frequency response (-3dB)	1 kHz, switchable to 20 Hz		
Measuring rate	max. 3.906 kSa/s		
Linearity ^[2]	< ±0.05 % FSO		
Temperature stability	< 200 ppm FSO/K		
Replaceability ^[3]	< ±0.1 % FSO		
Long-term stability	< ±0.02% FSO/month		
Synchronization	yes (only internal)	yes	
Supply voltage	12 ... 36 VDC		15 ... 36 VDC
Power consumption	3.1 W (24 VDC) + 1.8 W / demodulator		3.8 W (24 VDC) + 1.8 W / demodulator
Signal input	Trigger: TTL (5 V)		
Digital interface	Ethernet		Ethernet/EtherCAT
Analog output	0 ... 10 V / 4 ... 20 mA		
Connection	Sensor	Pluggable cable via triaxial socket	
	Supply/signal	Supply/trigger: 4-pin connector; sync: 5-pin connector; signal: analog via 4-pin connector, digital via RJ45 connector (for suitable connection cables, see accessories)	
Mounting	Table-top device or DIN rail		
Temperature range	Storage	-10 ... 75 °C	
	Operation	10 ... 60 °C	
Shock (DIN EN 60068-2-29)	15 g / 6 ms in 3 axes, two directions each, 1000 shocks each		
Vibration (DIN EN 60068-2-6)	0.75 mm / 10 ... 500 Hz in 3 axes, 2 directions and 10 cycles each 2 g / 10 ... 500 Hz in 3 axes, 2 directions and 10 cycles each		
Protection class (DIN EN 60529)	IP40		
Weight	approx. 710 g + 185 g / demodulator		approx. 720 g + 185 g / demodulator
Compatibility	Recommended for use with high-temperature sensors (CSE-x/HT models); generally compatible with all capaNCDT sensors		
No. of measurement channels	max. 4		

^[1] FSO = Full Scale Output | RMS noise referred to the end of the measuring range; static = 2 Hz, dynamic = maximum frequency response of the controller

^[2] Applies to the controller only. The total linearity of the measuring channel is the sum of the controller and sensor values.

^[3] FSO = Full Scale Output | The value corresponds to the slope error that occurs when a sensor is replaced without recalibration

DT6228 / DT6238

Pin assignment for power supply and trigger

Pin	Assignment	Color (cable PC6200-3/4)
1	Supply +24 V	Brown
2	GND supply	White
3	Trigger IN+, TTL level	Yellow
4	Trigger IN-	Green

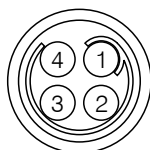

Solder side view,
4-pin socket

DT6228 / DT6238





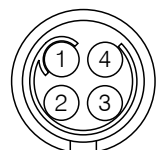

Pin assignment for analog output

Pin	Assignment	Color (color SCACx/4)
1	U _{OUT} (load min. 10 kOhm)	Brown
2	I _{OUT} (burden max. 500 ohm)	Yellow
3	Analog ground	Gray
4	Analog ground	White



Solder side view,
4-pin cable
connector

High-performance measuring system (up to 8 channels) capaNCDT 6500

-  Multi-channel system with subnanometer resolution
-  Analog output and digital interface (Ethernet / EtherCAT)
-  Data rate digital: up to 7.8 kSa/s
-  Integrated calculation function, e.g., for thickness measurements
-  Modular system scalable up to 8 channels
-  With internal or external preamplifier available
-  Intuitive operation via web interface



The capaNCDT 6500 offers maximum resolution and precision for up to 8 sensors. Inside the rugged aluminum housing, interchangeable and freely combinable demodulator modules ensure optimal signal processing for a wide range of measurement requirements.

The system is easily configured via an integrated web interface, which can be accessed via the Ethernet port. Features such as filtering and averaging, trigger functions, data logging, digital linearization, and arithmetic calculations allow for flexible adaptation to a wide variety of measurement tasks.

The demodulator version DL6530 has an integrated preamplifier. To improve accuracy or when using longer cables, one of the external preamplifiers (CP6001 or CPM6011) is used in conjunction with the DL6510 demodulator.

Variable sensor connections for maximum performance in your application

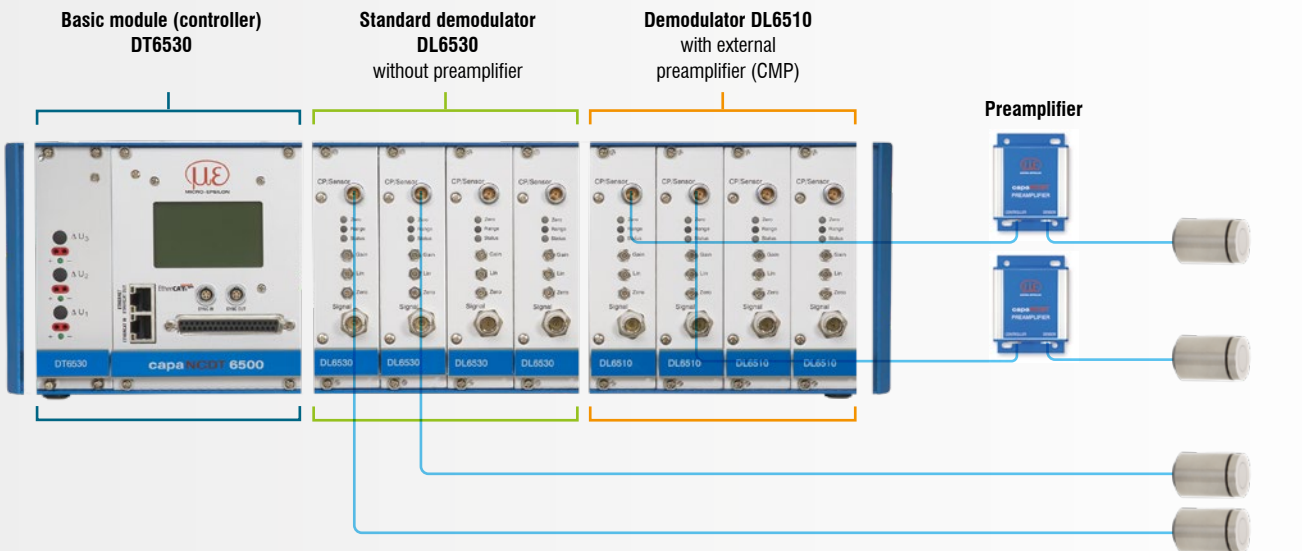

Max. 8 sensors on one DT6500

Model		DT6530		
Demodulator		DL6530	DL6510 with CP6001	DL6510 with CPM6011
Resolution ^[1]	Static	0.00003 % FSO		0.0006 % FSO
	Dynamic	0.002 % FSO		0.015 % FSO
Frequency response (-3dB)		8.5 kHz, switchable to 1 kHz, 20 Hz		
Measuring rate		4 x 7.8 kSa/s; 8 x 3.9 kSa/s		
Linearity ^[2]		< ±0.025 % FSO		< ±0.05 % FSO
Temperature stability		< 5 ppm FSO / K (digital); < 10 ppm FSO / K (analog)		< 80 ppm FSO/K
Replaceability ^[3]		< ±0.05 % FSO		< ±0.1 % FSO
Long-term stability		< ±0.004% FSO/month		< ±0.04% FSO/month
Synchronization		yes (internal + external)		
Supply voltage		230 VAC		
Power consumption		12 W + 3.2 W / demodulator		
Signal input		TTL (5 V)		
Digital interface		Ethernet (24 bits) / EtherCAT		
Analog output		0 ... 10 V (max. 10 mA, short circuit proof) / (0) 4 ... 20 mA (max. burden 500 Ω)		
Connection		Sensor: triax connector (DL6530) or 5-pin connector (DL6510); power supply: IEC connector; trigger/sync: 37-pin Sub-D connector; signal: analog via 37-pin Sub-D connector or BNC, digital via RJ45 connector (suitable connection cables, see accessories)		
Mounting		Table-top device or 19-inch rack		
Temperature range	Storage	-10 ... 75 °C		
	Operation	10 ... 60 °C		
Shock (DIN EN 60068-2-29)		20 g / 5 ms in 3 axes, two directions each, 1000 shocks each		
Vibration (DIN EN 60068-2-6)		1 mm / 10 Hz ... 49.8 Hz in 3 axes, 10 cycles each 10 g / 49.8 ... 2000 Hz in 3 axes, 10 cycles each		
Protection class (DIN EN 60529)		IP20		
Weight	Controller	Base system for max. 2 measuring channels: 3.5 kg; base system for max. 8 measuring channels: 6.0 kg		
	Demodulator	0.4 kg per equipped measuring channel (demodulator)	0.5 kg per equipped measuring channel (demodulator) and external preamplifier	
Compatibility		compatible with all capaNCDT sensors		
No. of measurement channels		max. 2 or max 8 (depending on the base system)		

^[1] FSO = Full Scale Output | RMS noise referred to the end of the measuring range; static = 2 Hz, dynamic = maximum frequency response of the controller

^[2] Applies to the controller only. The total linearity of the measuring channel is the sum of the controller and sensor values.

^[3] FSO = Full Scale Output | The value corresponds to the slope error that occurs when a sensor is replaced without recalibration

DT6530

Pin assignment analog output, trigger and synchronization

Pin	Assignment	Pin	Assignment	Pin	Assignment
1	U-Out channel 1	13	Trigger_In	25	AGND channel 6
2	U-Out channel 2	14	Sync_In-8M	26	AGND channel 7
3	U-Out channel 3	15	Sync_Out-8M	27	AGND channel 8
4	U-Out channel 4	16	Sync_In-31K	28	I-Out channel 2
5	U-Out channel 5	17	Sync_Out-31K	29	I-Out channel 4
6	U-Out channel 6	18	Not assigned	30	I-Out channel 6
7	U-Out channel 7	19	Not assigned	31	I-Out channel 8
8	U-Out channel 8	20	AGND channel 1	32	GND_Trigger_I
9	I-Out channel 1	21	AGND channel 2	33	Sync_In+ 8M
10	I-Out channel 3	22	AGND channel 3	34	Sync_Out+ 8M
11	I-Out channel 5	23	AGND channel 4	35	Sync_In+ 31K
12	I-Out channel 7	24	AGND channel 5	36	Sync_Out+ 31K
				37	Not assigned

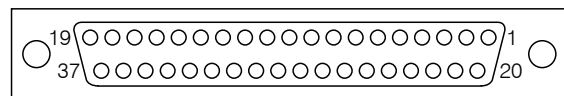

Solder side view, 37-pin Sub-D cable connector

Controller dimensions

capaNCDT

DT6110, DT6112, DT6120

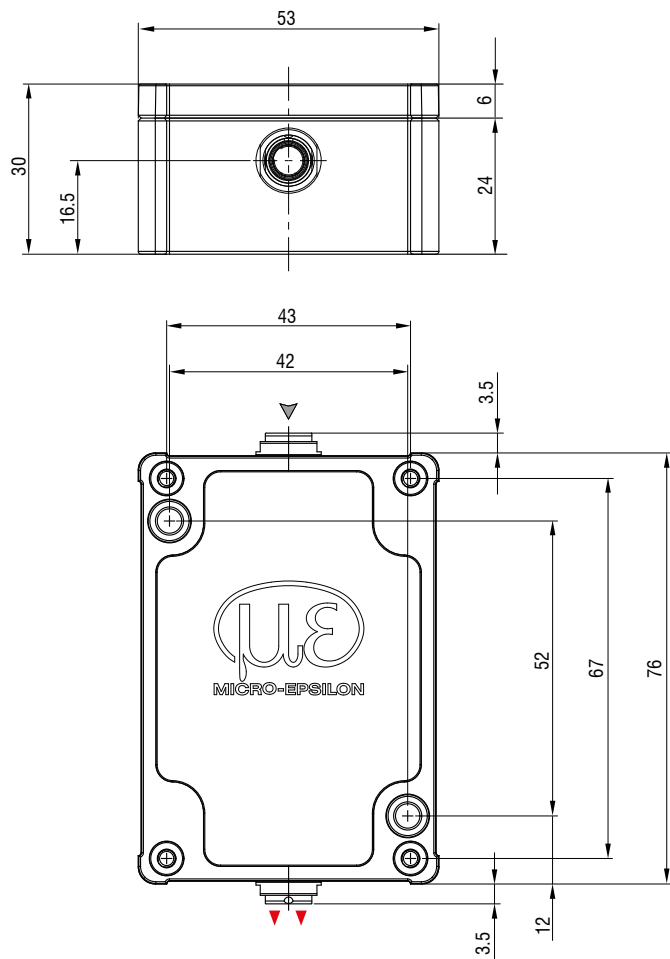

DT6110/IP, DT6120/IP

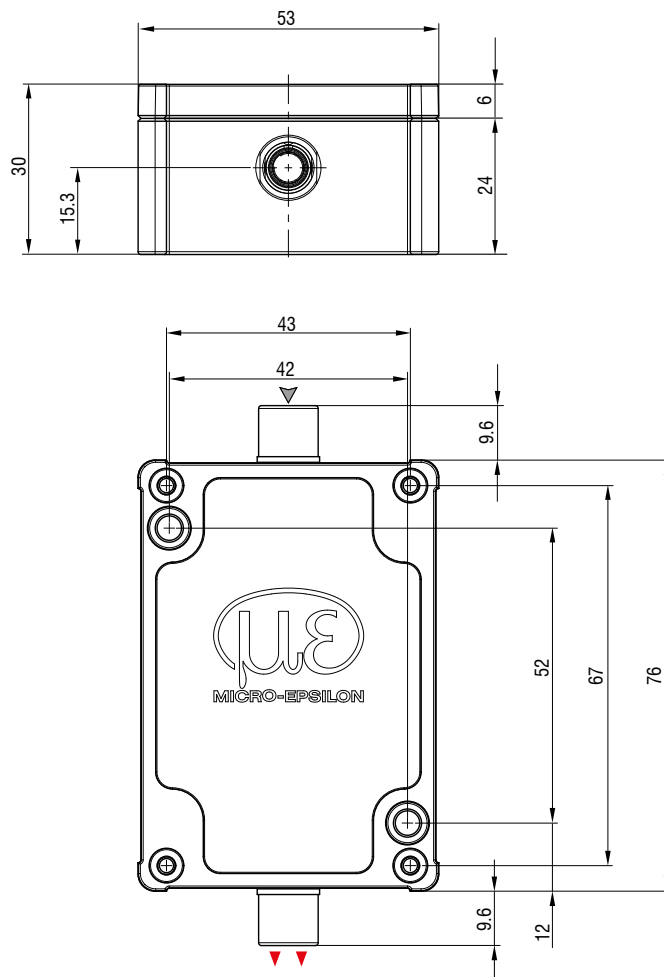

DT62xx

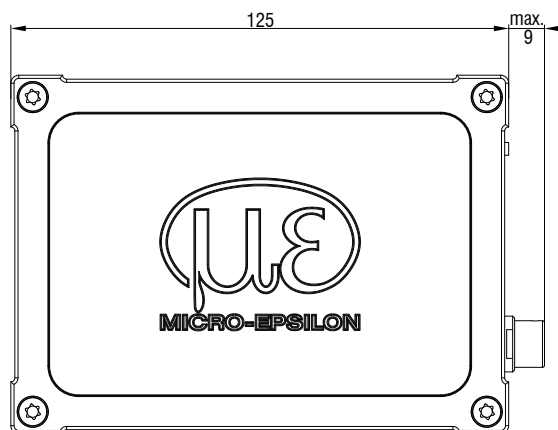
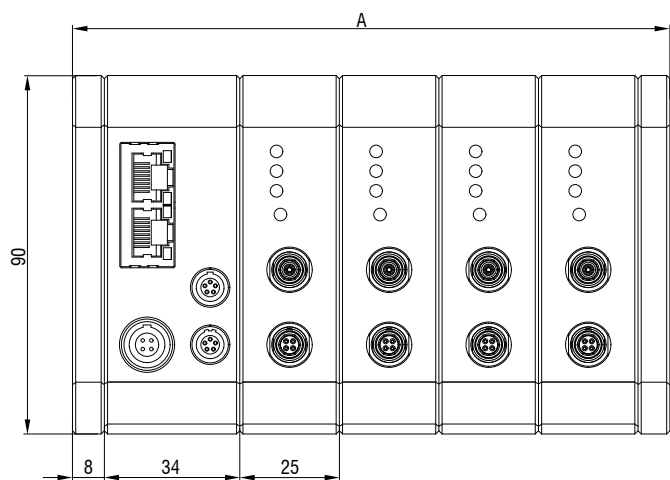

No. of channels	A (mm)
1	75
2	100
3	125
4	150

DT6530

If there are three or more measuring channels, the housing length remains the same.
 A shorter housing version is available as an option for systems with one or two measuring channels.

Dimensions for 3 to 8 measuring channels

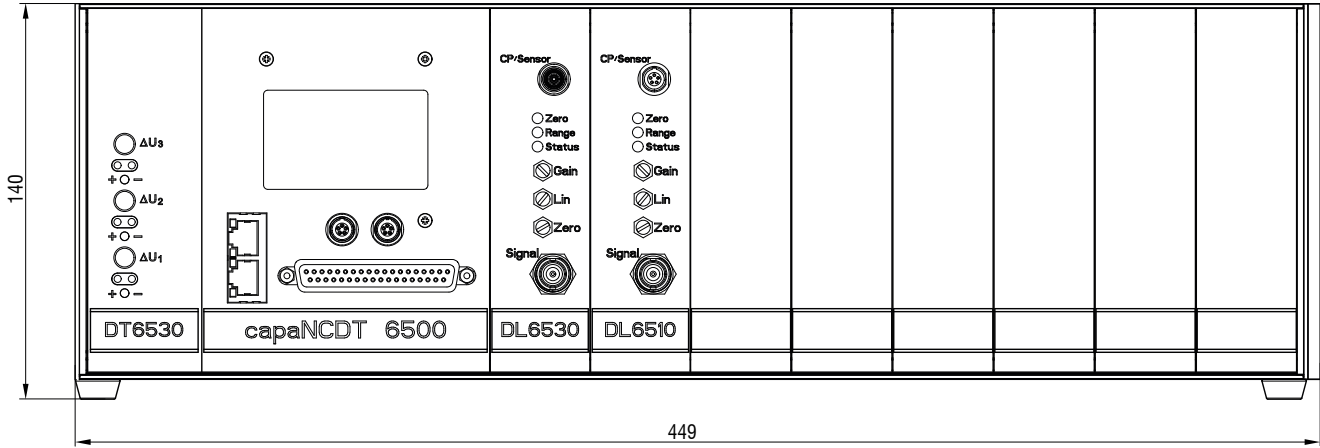

Dimensions for 1 to 2 measuring channels

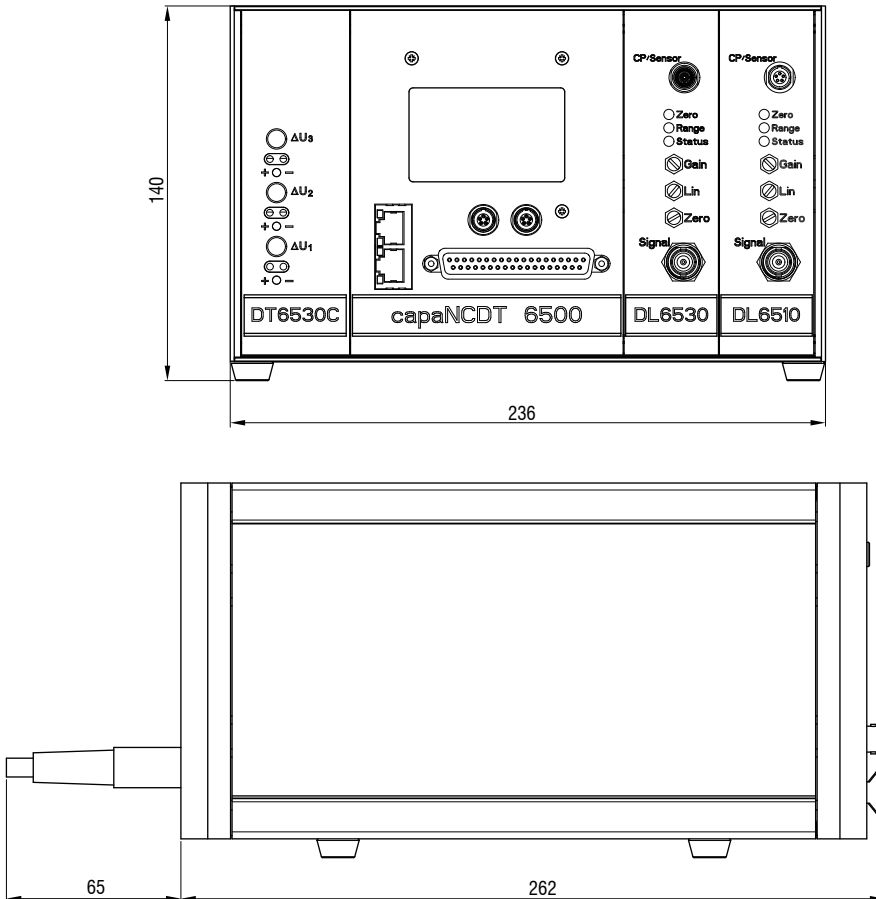

Connections and combinations

capaNCDT

Controller



DT6100



DT6200



DT6500

Sensor cable



Type: CCg

Robust triaxial cable for industrial applications
 Cable diameter: 3.1 mm (± 0.1 mm)
 Minimum bending radius: static approx. 10 mm /
 dynamic approx. 30 mm
 Temperature resistance: -20 ... +85 °C (permanent) /
 -20 ... +100 °C (limited to 10,000 h)
 Standard length: 2 m (optional lengths see p. 41)

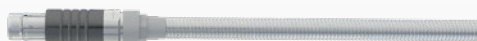

Type CCg/PT

Crush-resistant triaxial cable with protective metal tubing
 Cable diameter: 6 mm (± 0.15 mm)
 Minimum bending radius: static approx. 20 mm /
 dynamic approx. 30 mm
 Temperature resistance: -20 °C ... +85 °C (permanent) /
 -20 ... +100 °C (limited to 10,000 h)
 Standard length: 2 m (optional lengths see p. 41)



Type CCm

Low-outgassing triaxial cable for UHV and cleanroom
 Cable diameter: 2.1 mm (± 0.1 mm)
 Minimum bending radius: static approx. 7 mm /
 dynamic approx. 25 mm
 Temperature resistance: up to -100 ... 200 °C
 Standard length: 1.4 m (optional lengths see p. 41)



Type CCo

Low-outgassing triaxial cable for high temperatures
 Cable diameter: 3.1 mm (± 0.1 mm)
 Minimum bending radius: static approx. 10 mm /
 dynamic approx. 30 mm
 Temperature resistance: -20 ... +200 °C
 Standard length: 2 m (optional lengths see p. 41)

Sensors with integrated cable use the cable types CCM and CCg

Type CCM

Low-outgassing triaxial cable for UHV and cleanroom
 Cable diameter: 2.1 mm (± 0.1 mm)
 Minimum bending radius: static approx. 15 mm /
 dynamic approx. 30 mm
 Temperature resistance: up to 200 °C
 Standard length: 1.4 m (optional lengths see p. 41)

Type CCg

Robust triaxial cable for industrial applications
 Cable diameter: 3.1 mm (± 0.1 mm)
 Minimum bending radius: static approx. 10 mm /
 dynamic approx. 30 mm
 Temperature resistance: -20 °C ... +85 °C (permanent) /
 -20 ... +100 °C (limited to 10,000 h)
 Standard length: 2 m (optional lengths see p. 41)

Plug connector



Type B connector



Type B / 90 connector



Type B / IP connector



Type C connector



Type C / 90 connector



Type E connector

Sensors with socket



CS-x, CSE and CSE/Mx models
with a measuring range from 1 mm

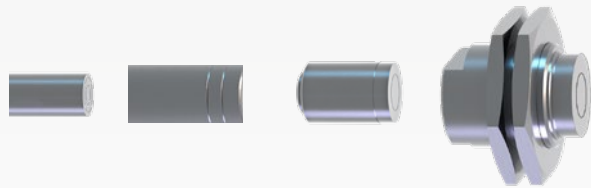

CS, CS-x, CSE and CSE/Mx models
with measuring range up to 1 mm



CSF flat sensors with socket

Sensors with integrated cable



Connection accessories and signal cables

capa**NCDT**

Controller accessories								
Article		Description	DT65xx	DT62xx	DT611x	DT6120	DT61x0/IP	
SCACx/4		Analog signal cable 4-pin with XYZ connector / open ends Standard length: 3 m Optional lengths available: 6 m / 10 m / 12 m / 15 m		X				
PC6200-x/4		Power supply and trigger cable 4-pin with XYZ connector / open ends Standard length: 3 m Optional lengths available: 5 m / 15 m		X				
SC6000-x		Power supply and trigger cable 5-pin with XYZ connector / open ends Standard length: 0.3 m Optional lengths available: 3 m / 5 m / 15 m	X	X				
SCACx/5		Power supply and signal cable 5-pin with XYZ connector / open ends Standard length: 3 m Optional lengths available: 4 m / 5 m / 6 m / 8 m / 15 m			X			
SCACx/6		Power supply and signal cable 6-pin with XYZ connector / open ends Standard length: 3 m				X		
SCACx/6/IP		Power supply and signal cable IP68 6-pin with XYZ connector / open ends Standard length: 3 m					X	
CAx		Pre-amplifier connection cable 5-pin with XYZ connector both ends Standard length: 3 m Optional lengths available: 5 m / 10 m / 15 m / 20 m	X					
CMP6011		External preamplifier for standard measurements	X					
CP6001		External preamplifier for high precision measurements	X					
PS2020		Power supply unit Input 100-240 VAC Output 24 VDC / 2.5 A Mounting on a symmetrical DIN rail 35 mm x 7.5 mm DIN 50022		X	X	X	X	
IF1032		Interface module for Ethernet/EtherCAT			X	X	X	

CPM6011

External preamplifier

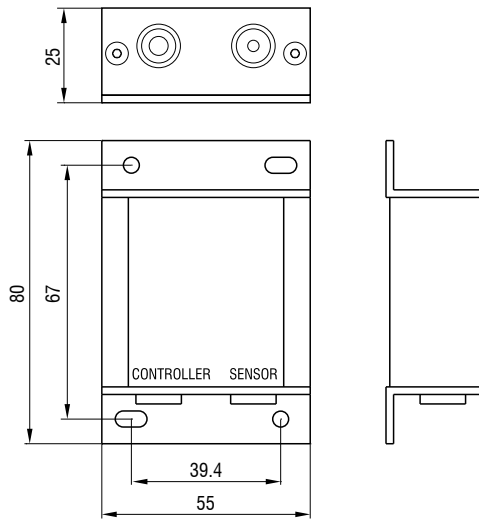

CP6001

External preamplifier

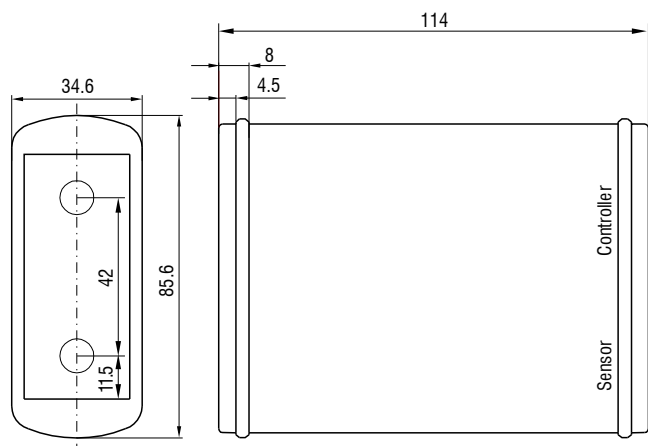

Mounting bracket for CP6001

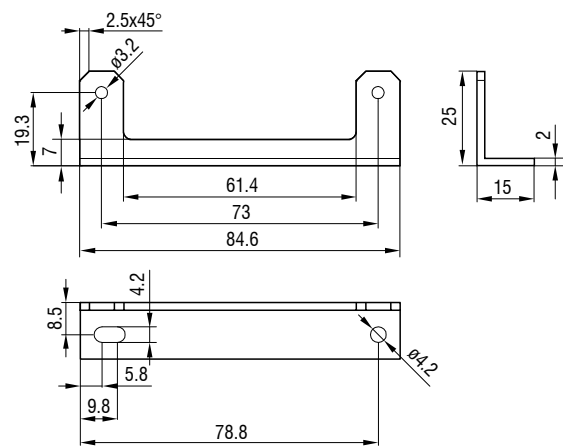

IF1032

Interface module

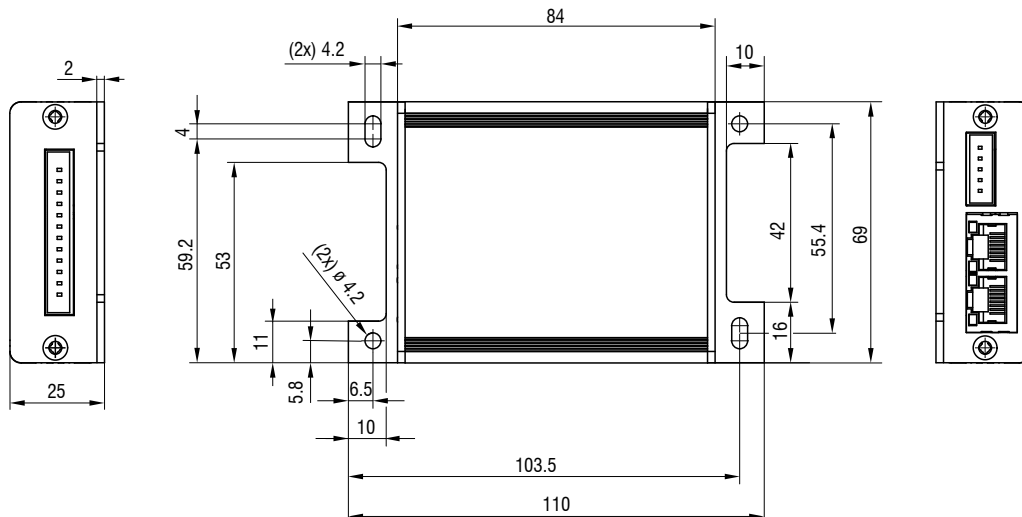

Vacuum feedthroughs

Micro-Epsilon offers a variety of vacuum feedthroughs for the quick and easy integration of capacitive sensors in high-vacuum and ultra-high-vacuum environments. The feedthroughs are available as screw-in or weld-in versions, or with a large flange. All models are designed for sensors with a type B connector. Feedthroughs for sensors with connector types C and E are available upon request.

Vacuum feedthrough screwable

Art. no. 0323050

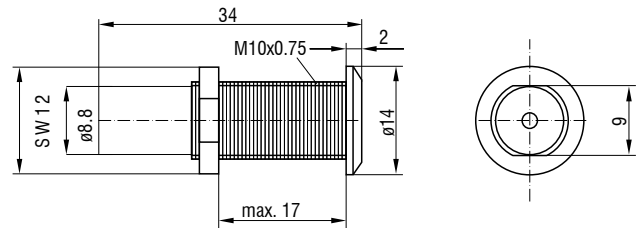

Maximum leak rate: 1×10^{-7} mbar-l-s⁻¹, compatible with type B connectors

Vacuum feedthrough weldable

Art. no. 0323346

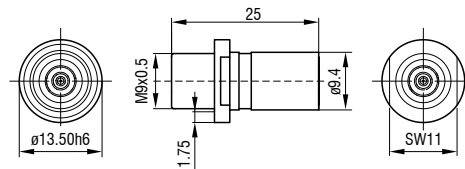

Maximum leak rate: 1×10^{-9} mbar-l-s⁻¹, compatible with type B connectors

Vacuum feedthrough with flange (CF16)

Art. no. 0323349

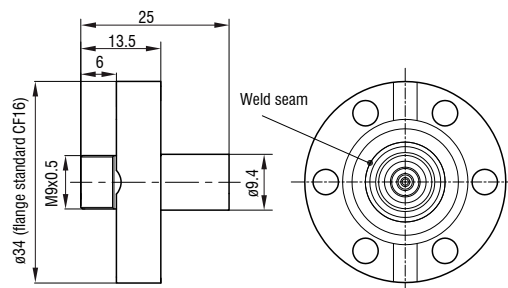

Maximum leak rate: 1×10^{-9} mbar-l-s⁻¹, compatible with type B connectors

Mounting accessories

MA-CS-2-C

Mounting frame for two-sided thickness measurements
C-frames for capacitive sensors (with calibration target)
for up to 2 measurement tracks / 4 capacitive sensors



MA-CS3

Mounting frame for two-sided thickness measurements
C-frame for capacitive sensors for up to 3 measurement tracks /
6 capacitive sensors



Calibration target attachment mounting frame

compatible with MA-CS-2-C for optional on-site calibration

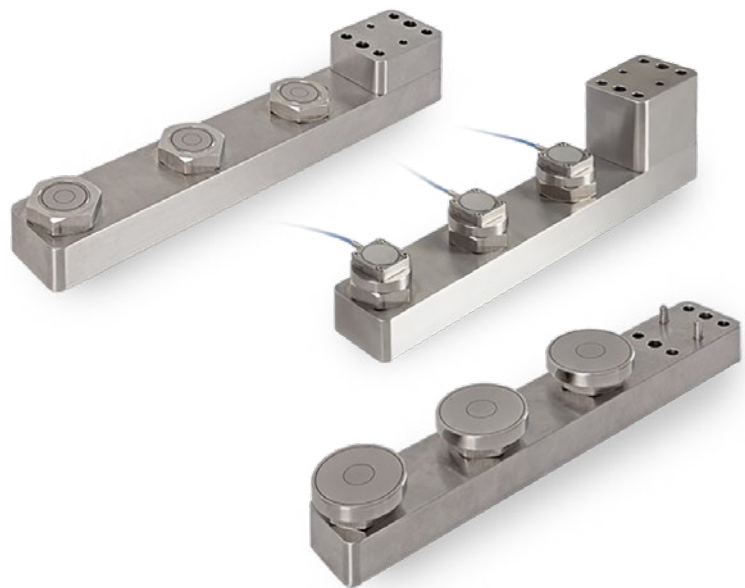

Accessories for flat sensors

Air purge collar for gap sensors

CSG-0,5/CRg2,0 and CSG-1/CRg2,0

The compressed air connection allows for continuous removal of dust and debris from the measuring surface, ensuring consistently accurate measurement results.



Technical details

capaNCDT

Minimum diameter of the measuring object

The relative size of the target has effects on the linearity deviation. Ideally, the object being measured should be at least as large as the "Recommended target size" specified in the technical data, or at least as large as the sensor's diameter. In this case, the sensor's full measuring range can be used without the need for additional calibration. Measuring objects smaller than the sensor diameter require a special calibration. The smaller the size (ratio measurement electrode and measuring object), the lower the accuracy.

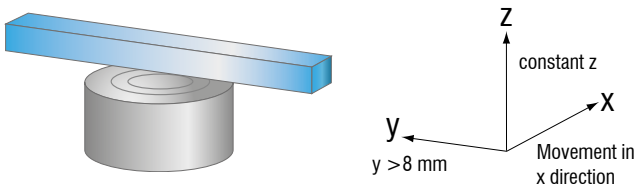
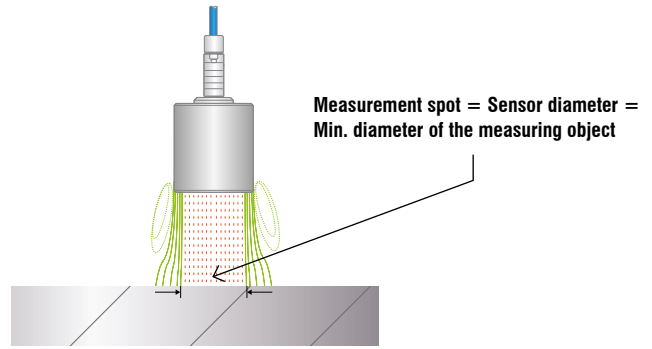

Measurement on narrow targets

The width of the object being measured affects the capacitive measurement signal. Simulations using a CS05 sensor (8 mm diameter) as an example show that even narrow objects can be measured reliably, provided they are sufficiently large and correctly positioned.

At a distance of 0.25 mm (mid of measuring range), even a centrally positioned object 5 mm wide produces a stable measurement signal. The larger the distance between the sensor and the measuring object, the larger the required minimum width.

The results show that the electric field does not extend beyond the entire diameter of the sensor. This makes it possible to take precise measurements even on narrow objects.

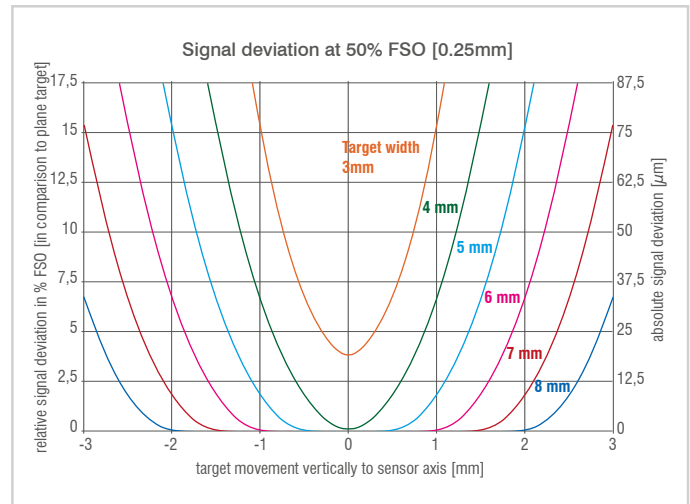

Conductivity of the measuring object

In order to achieve a linear output signal across the complete measuring range, certain requirements for the target or the counter electrode must be complied with. The impedance in the ideal plate capacitor can be shown in the equivalent circuit diagram by a capacitor and a resistor connected in parallel. For measurement against metals, the ohm part can be disregarded; the impedance is only determined by the capacitive part. Conversely, only the ohm part is considered for measurements against insulators.

In between, there is the large range of semiconductors. Most semiconductors can be measured very well as electrical conductors. The requirement is that the capacitive part of the total impedance is still significantly larger (>10x) than the ohmic part. This is almost always the case for silicon wafers irrespective of the endowment. Nevertheless, semiconductors with poor conductivity (e.g. GaAs) can also be measured as conductors under certain circumstances.

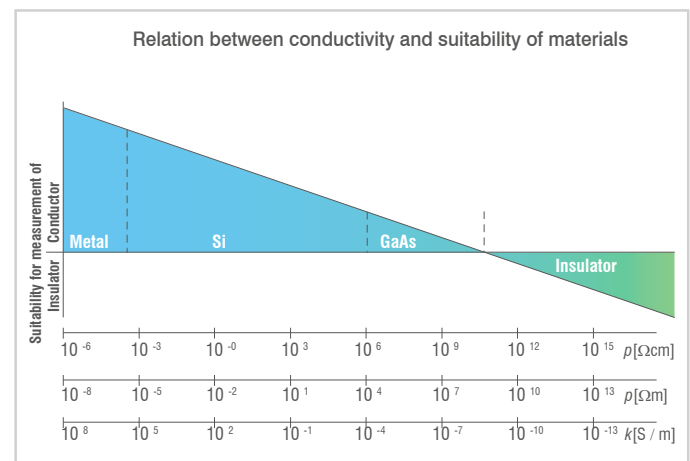

However, various adjustments are required for this, e.g. reduction of the operating frequency or a temporary, partial increase of the conductivity.

Minimum diameter of round measuring objects:

When measuring distances on curved surfaces such as when measuring wave patterns on rollers, measurement errors may occur. This is caused by the altered field line distribution and an enlarged effective measurement spot, which changes the measured capacitance. In practice, this results in a virtual zero point for the sensor, meaning that the measurement value of 0 μm is no longer

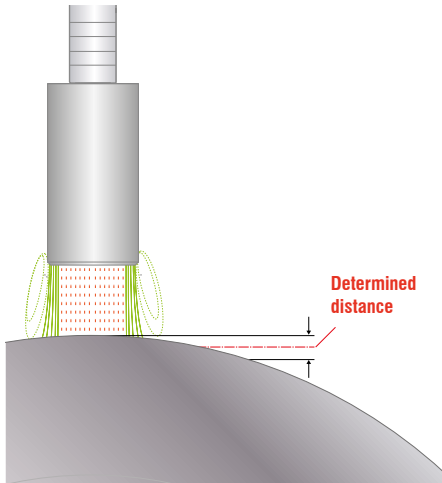

Example: For a sensor with a 200 μm measuring range and a roller with an outer diameter of 30 mm, an actual gap of 20 μm results in a measured value that is approximately 5 % higher. This corresponds to approx. 10 μm of the measuring range.

achieved. Since capacitive sensors integrate over their entire measuring surface, the virtual mean measurement plane lies behind the actual generatrix of the cylindrical target object. As this effect is predictable, corresponding correction curves can be stored in the controller.

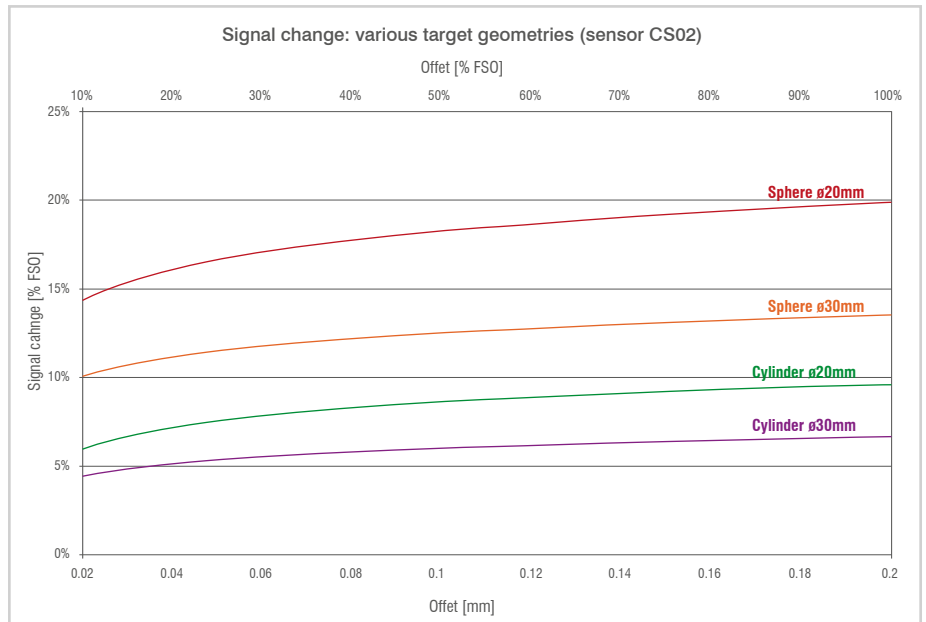

Inclination:





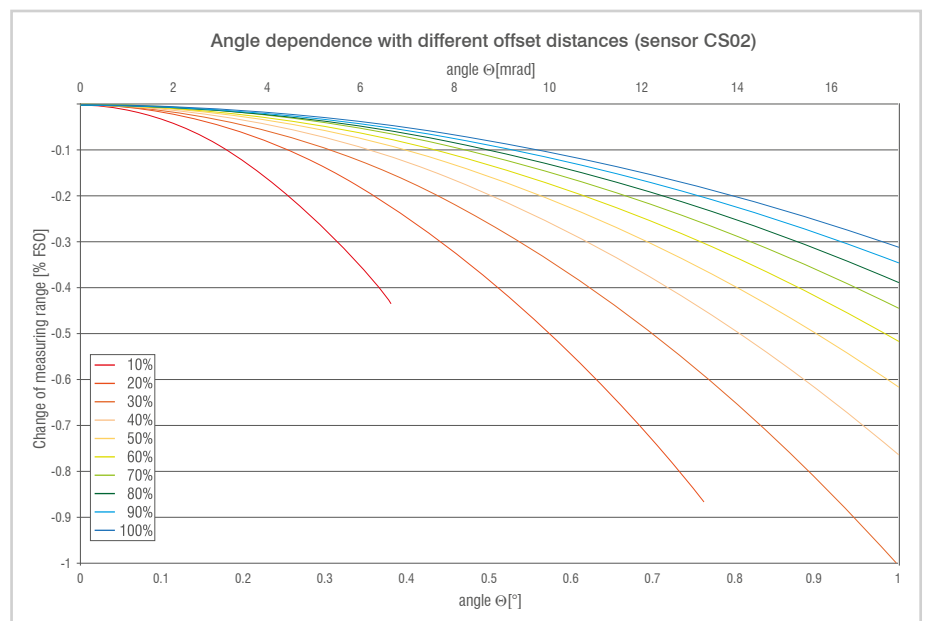
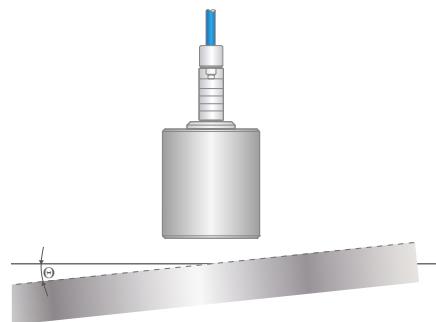

If the capacitive sensor or the measuring object is tilted, an error is likely to occur, as the geometric conditions of the field relative to the object being measured change. In fact, the average distance of the sensor remains constant; however, the edge areas move closer or further away from the target. The following figure illustrates this effect using the CS02 sensor as an example, with a maximum tilt angle of

1° at various sensor distances. At a 10 % offset along the sensor axis, contact between the sensor housing and the measuring object occurs at 0.38°; at a 20 % offset, contact occurs at 0.76°. The simulation can be performed for all sensors and installation conditions; tilt angles around a decentralized tilt point can also be calculated.



Sensor system for thickness measurement of plastics

combiSENSOR KSS6420

-  One-sided thickness measurement in one axis
-  Integrated temperature measurement
-  Special plug for fast sensor connection
-  Thickness measurement based on ϵ_r
-  Determination of ϵ_r with known thickness
-  Operation via web interface



In its sensor housing, the combiSENSOR combines an eddy current displacement sensor and a capacitive displacement sensor. This unique sensor concept enables one-sided thickness measurement of electrically non-conductive materials on metallic objects. Its field of application is the absolute thickness measurement of plastic film or of plastic coating on metal plates.

The sensor is wired to the controller, which processes and calculates the signals in order to put them out via interfaces. Calculation of the two sensor signals provides compensation of mechanical changes such as thermal expansion, deflections or eccentricity in the measurement device. Due to the redundancy of this combined sensor principle, the measured thickness value remains extremely stable. Due to the high temperature stability, the combiSENSOR provides high measurement accuracy even with fluctuating temperatures.

Controller	KSS6420	KSS6430	KSS6420(01)	KSS6430(01)
Sensors	KSH5(01)		KSH10	
Measuring range, thickness (insulator)	40 μm ... 3 mm		40 μm ... 6 mm	
Working distance	2 mm ... 5 mm		4 mm ... 10 mm	
Resolution (100 Hz)	0.0018 % FSO	0.0004 % FSO	0.0030 % FSO	0.0006 % FSO
Bandwidth	analog: 1 kHz (3 dB), digital: 2.6 ... 3900 Sa/s (adjustable)			
Linearity	± 0.05 % FSO			

Fields of application

- Non-contact thickness measurement of plastic films
- Non-contact thickness measurement of coated metals
- Measurement of the applied adhesive
- Lateral profile due to a traversing axis

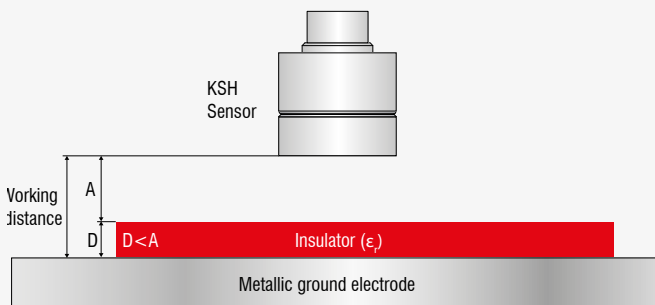

Thickness measurement D

If the dielectric constant ϵ_r and the working distance from the ground electrode are known, the controller calculates the insulator thickness D from the sensor signals.

Calculation of the dielectric constant ϵ_r

If the thickness of the Insulator D and the working distance from the ground electrode are known, the controller calculates the dielectric constant of the insulator.





Measuring principle

The eddy current coil and the capacitive measurement electrodes are designed concentrically. Both sensors measure against the same spot. The signal from the capacitive displacement sensor indicates the distance to the upper layer (e.g., insulator or electrode coating). At the same time, the eddy current sensor measures the distance to the lower layer (e.g., beneath a sheet of metal or a metal roller).

The controller outputs both single signals as well as the difference between capacitive sensor and eddy current sensor. If the thickness and working distance are known, the dielectric constant can also be calculated.

Sensor system for precise thickness measurement of electrode coatings

combiSENSOR KSB6430

-  Extremely high-temperature resistance and stability from -10 °C to + 180 °C
-  **INTER FACE** PROFINET / EtherNet/IP, EtherCAT
-  One-sided thickness measurement with a target thickness from 5 μm to 3 mm
-  Repeatability from 0.5 μm
-  Measurement on steel rollers with chrome coating



The combiSENSOR KSB combines an eddy current sensor and a capacitive displacement sensor in a single housing, enabling precise, non-contact thickness measurement of electrode coatings on metallic surfaces.

Its high temperature stability allows for the combiSENSOR to provide constant measurement values even at fluctuating ambient temperatures. In addition, the sensor is resistant to soiling which makes it ideal for harsh industrial applications where reliability and precision are crucial factors.

Controller	KSB6430
Sensor	KSH5(03)
Measuring range (thickness)	5 μm ... 3 mm
Working distance	2 mm ... 5 mm, best performance at 2.5 mm ... 4.0 mm
Resolution (100 Hz)	0.02 μm
Repeatability	$\pm 0.5 \mu\text{m}$
Frequency response (-3dB)	1 kHz

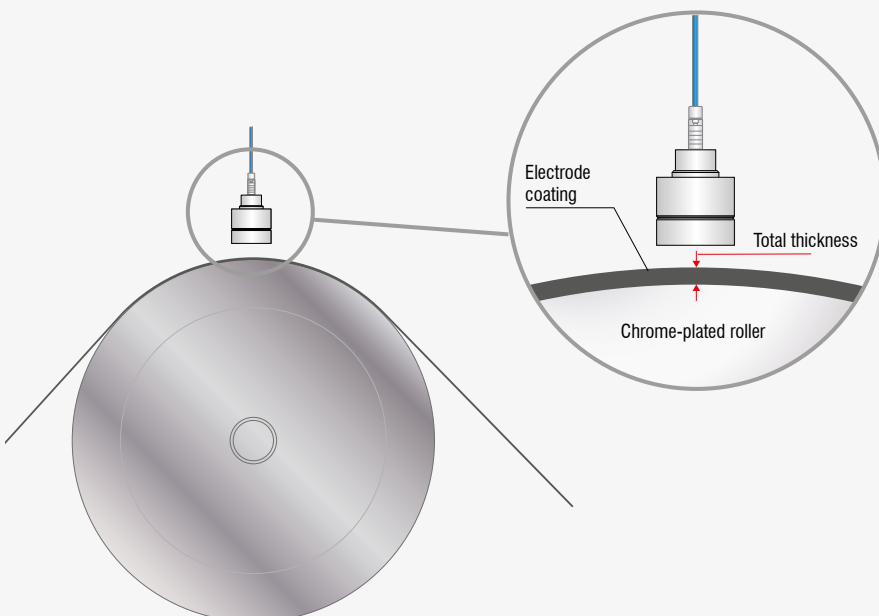





Measuring principle

The combiSENSOR KSB measures the coating thickness with a capacitive sensor to measure the distance from the coating and an eddy current sensor to measure the distance from the metal roller.

The difference between the two signals provides the total thickness of the medium, while mechanical influences are automatically compensated for.

Active measuring system for long signal transmission paths

capaNCDT 61x4

-  Ideal for long signal transmission paths up to 15 m
-  Robust sensor cable for use on drag chains and robots
-  Easy integration due to flexible cable routing
-  Highest signal stability even with sensor cable in motion
-  **INTERFACE** RS485 interface or analog output



The capaNCDT 61x4 is an active capacitive system for industrial distance measurement with long cables. Consisting of a sensor with integrated preamplifier, a robust cable and a compact controller, the measuring system is immediately ready for use. The integrated preamplifier allows the sensor to bridge long signal transmission paths while maintaining high signal stability.



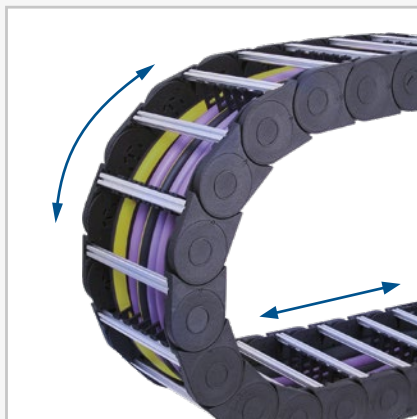

With cable lengths up to 15 m, the capaNCDT 61x4 is used in automation applications with drag chain guides, in robotics, and in semiconductor machine building. For optimum signal quality, the desired cable length is already factory-calibrated. The active flat sensor is designed with a ceramic sensor element and impresses with its compact and robust design.

Controller	DT6114/5	DT6114/15	DT6124/5	DT6124/15
Sensors	CSHA2FL-CRa5 (5 m cable) CSHA2FL-CRa15 (15 m cable)			
Measuring range, nominal	2 mm			
Resolution (2 Hz)	0.01 % FSO			
Frequency response (-3dB)	1 kHz			
Measuring rate	-	-	Selectable: max. 2 kSa/s	Selectable: max. 2 kSa/s
Linearity	< ±0.1 % FSO	< ±0.25 % FSO	< ±0.1 % FSO	< ±0.25 % FSO
Temperature stability	< 100 ppm FSO/K			



Offering high flexibility and lengths up to 15 m, the robust capaNCDT 61x4 cables are ideally suited to measurement tasks on robots and in automation technology.

Off-line measuring system for thin films capaNCDT TFG6220

-  Thickness measurement of very thin, electrically conductive film <1 mm
-  Automatic smoothing of the film by vacuum
-  Turnkey measuring system with robust design
-  Immediately ready for operation - reliable measurements at the touch of a button
-  Simple operation/visualization via the sensorTOOL



The TFG6220 measures the thickness of electrically conductive film, e.g. battery film, with maximum precision. The TFG6220 is used for qualification, offline testing of samples, and quality control. A vacuum device sucks in the object to be measured, smooths it and thus ensures wrinkle-free support. This allows the measurement to be performed with maximum precision without compressing the target object or applying point loads to it.

The TFG6220 consists of a measuring bracket including capacitive sensors and an external controller unit. Pre-assembled and ready for use, this capacitive measuring system can be started quickly.



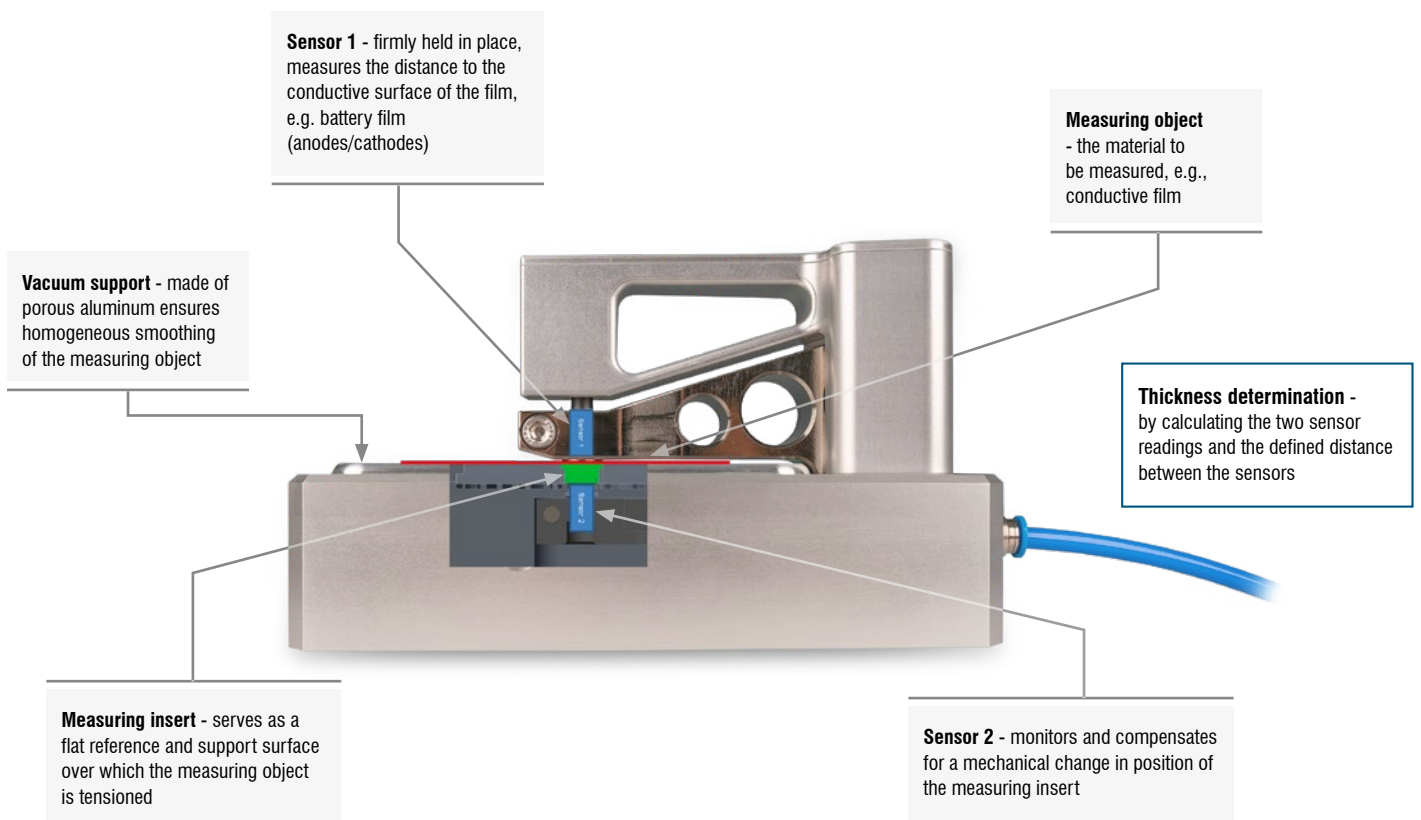

Model	TFG6220
Resolution (100 Hz)	10 nm
Max. measuring object/film thickness	< 1 mm
Measuring rate	100 Hz with median filter width 7
System accuracy	up to 0.2 μm
Measuring object	Electrically conductive material (> 106 S/m)
Recommended target size (flat)	110 mm x 110 mm

The sensorTOOL software offers a user-friendly interface for operating the capaNCDT TFG. It enables the user to perform the measurements and to display and output measured data. The software is available free of charge at www.micro-epsilon.com/download.



Rotation speed measuring system for industrial counting tasks

capaNCDT CST6110

-  Material-independent rotation speed measurement of 1 ... 400,000 rpm
-  Adjustable rotary switch (max. 16) for rotation output
-  Measurement from the first detection
-  Easy integration due to compact sensor size
-  Ideal for industrial environments with electromagnetic radiation



The capaNCDT CST6110 is a capacitive measuring system for non-contact rotation speed measurement of conductive measuring objects such as metals and non-conductive objects such as ceramics or plastics. This non-contact measurement is performed, for example, in drives, on rotor blades or on position marks of shafts.

The sensor can be mounted in axial and radial direction to the target in order to detect objects such as blades, teeth, rings or nubs. The measuring range from 1 to 400,000 rpm enables the detection of both the startup from the first rotation and high rotational speeds reliably.

The adjustable rotary switch supports the rotation output of objects which have several measuring points per rotation, e.g., rotor blades. Data output is via a voltage output or a digital interface.

The CST6110 rotation speed system consists of a compact industrial sensor which is connected to the robust controller via a sensor cable.

Controller	CST6110
Sensor	CS025/M5-CAM1,0/RS with a measuring range of 0.25 mm
Speed range (measuring range)	1 ... 400,000 rpm
Start of measuring range	max. sensor distance from measuring object is 1 mm
Frequency response (-3dB)	110 kHz
Linearity	< ±0.2 % FSO
Target material	Electrically conductive / non-conductive

The sensor design with M5 thread allows for secure mounting in environments with limited installation space. Its interference immunity enables it to operate the system in environments with electromagnetic fields.



Axial installation: rotation speed monitoring on shafts





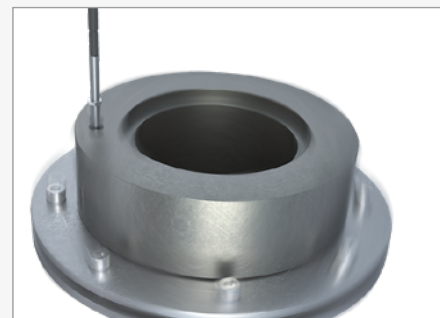

Radial installation: measurement in turbines



Axial installation: rotation speed in drilling rigs

Mobile gap measurement capaNCDT MD6-22

-  High-precision gap measurement
-  Intuitive operation
-  For all electrically conductive measuring objects
-  Comprehensive sensor portfolio
-  Cable lengths up to 4 m



The capaNCDT MD6-22 gauge is a capacitive dual-channel handheld gauge which is compatible with all capacitive sensors from Micro-Epsilon. This measuring system is used in mobile gap and distance measurements and impresses with high accuracy, versatile application possibilities and intuitive operation.

Supported with up to 5h battery life and storage of measurement data on SD card, the MD6-22 is ideally suited to mobile applications in service and maintenance tasks. For example, it is used for rotor gap monitoring in wind turbines and to measure the air gap between the turbine blade and the housing.

Included in delivery:

- Robust carry case
- Handheld measuring instrument MD6-22
- capaNCDT sensor with integrated cable
- Power supply unit / international / 24V / DC / 1A
- Magnetic holder incl. Allen wrench for installation
- 4 x NiMH/Mignon batteries (AA, HR6)
- Cable for ground connection

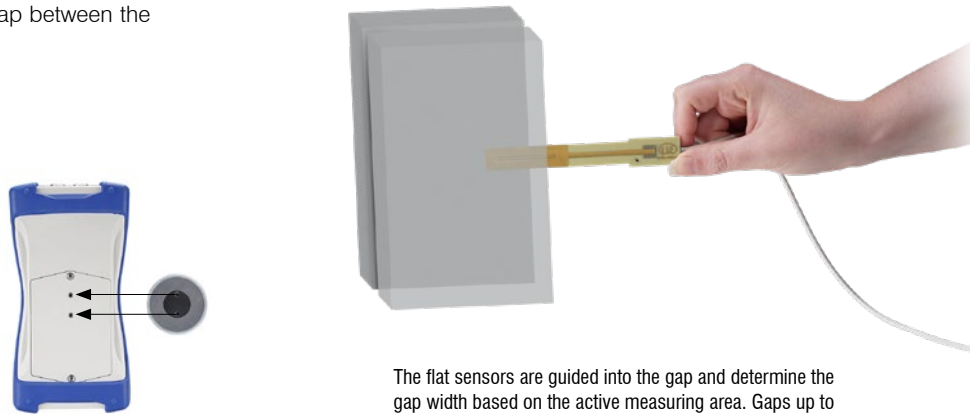

The flat sensors are guided into the gap and determine the gap width based on the active measuring area. Gaps up to 12 mm can be detected reliably.

Model	MD6-22
Sensors	compatible with all capaNCDT sensors
Resolution (100 Hz)	0.02 % FSO
Linearity	< ±0.2 % FSO
Number of measurement channels	2
Battery life	5 hours (with 2500 mAh)

This handheld measuring instrument offers four different measurement modes:

Single-sided gap measurement



Mode for optimal gap measurement on curved surfaces with gap sensors measuring one side (sensor alignment subordinated).

Single-value measurement with math function

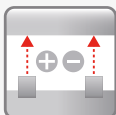

Mode for signal calculation of two sensors measuring one side.

Double-sided gap measurement





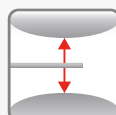

Mode for precise gap measurement on flat surfaces with compensation of sensor alignment. Gap sensors measuring two sides are used.



Mode for optimal gap measurement on curved surfaces with gap sensors measuring two sides (sensor alignment subordinated).

Robust multi-channel system for thickness measurement of brake discs capaNCDT DTV

-  Robust multi-channel sensor for multi-track measurements
-  **+800°C**
High temperature sensors up to +800 °C
-  For dynamic measurements
-  Comprehensive software package
-  Successful in test benches and road tests



The capaNCDT DTV is designed for non-contact measurement of brake disc thickness and Disc Thickness Variation. Thickness measurements can be carried out in test benches, in road tests or in car repair shops. The measurement is performed using capacitive displacement sensors that measure the thickness of the brake disc from two sides. The thickness is determined by using the difference principle. If the brake disc rotates, the thickness deviation is determined over the entire disc circumference. Using several sensors in pairs enables multi-track thickness measurements. For multi-track measurements, a robust sensor with 4 measuring surfaces is available.

Capacitive controller for dynamic measurement tasks

Combined with the DT6220 controller, four sensor channels can be processed synchronously. Due to the high bandwidth, dynamic measurements up to 5 kHz (-3dB) are possible. Data output is via an analog output or a digital Ethernet/EtherCAT interface. A web interface enables the configuration of the sensor and controller.

Controller	DT6229(02)/DTV
Sensors	recommended for use with CS-x series sensors; also compatible with CSE/HT series sensors or the special CSH1,4FL 4-channel sensor
Frequency response (-3dB)	max. 5 kHz, switchable
Sensitivity deviation	< ±0.1 % FSO
Data rate (digital output)	max. 3.906 kSa/s
No. of channels	max. 4

Software for DTV evaluation

Special DTV software calculates and delivers thickness values over time, providing real-time evaluation of measured results.

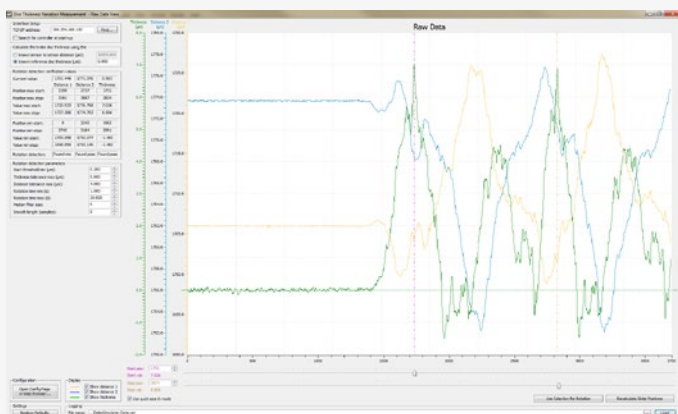
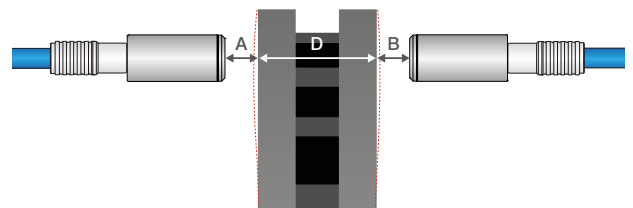





Software for DTV measurement

- Automatic and manual detection of rotation via peak-to-peak evaluation
- Print and memory
- Automatic compensation with perforated brake discs
- Free software updates

Compact multi-channel controller for OEM

capaNCDT 62x9

-  Controller with 2, 4 or 8 channels
-  **INTER FACE** Ethernet / EtherCAT interface
-  Supports triggering and synchronization
-  Robust, industrial housing with extremely compact design
-  **Best price** Excellent price-performance ratio for OEM series



designed for advanced
O/E/M

The capaNCDT 62x9 is a capacitive OEM displacement measuring system that stands out due to its favorable price-performance ratio and its compact design. The measuring system consists of a controller and one or two demodulators, each capable of handling up to four sensors. The capaNCDT 62x9 is compatible with all sensor models from Micro-Epsilon.

Ultra-compact controller for multi-channel applications

With a demodulator and four measuring channels, the controller is about half the size of a standard controller with the same number of channels. With two demodulators and up to 8 measuring channels, the space savings are even greater. The controller has a rugged aluminum housing and can be used as a benchtop unit or mounted on a DIN rail using an adapter.

The Ethernet interface integrated in the DT6229 controller allows for easy configuration via a web browser. With the integrated EtherCAT interface, the DT6239 offers an additional feature and the possibility to synchronize multiple controllers.

Controller type 62x9	Demodulator DL 6229
Resolution static	0.0004 % FSO
Data rate (digital output)	max. 3.906 kSa/s
Linearity (typ.)	≤ ±0.02 % FSO
Sensitivity deviation	±0.1 % FSO
Long-term stability	≤ 0.02 % FSO / month
Temperature stability	200 ppm/K

A measuring system consists of:

- Controller DT62x9
- Demodulator DL6229
- up to 4x sensor
- up to 4x sensor cable
- Power supply cable
- Ethernet cable / EtherCAT cable

DT6229 with 2 or 4 measuring channels DT6229 with 6 or 8 measuring channels



Sensors and Systems from Micro-Epsilon



Sensors and systems for displacement, distance and position



Sensors and measurement devices for non-contact temperature measurement

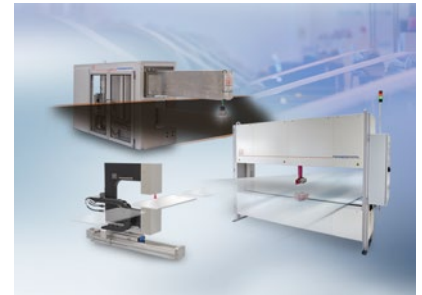

Measuring and inspection systems for metal strips, plastics and rubber



Optical micrometers and fiber optics, measuring and test amplifiers



Color recognition sensors, LED analyzers and inline color spectrometers

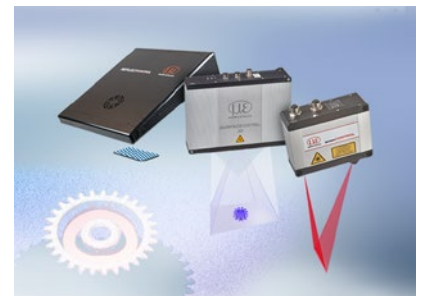

3D measurement technology for dimensional testing and surface inspection