



# More Precision.

Displacement and position sensors  
for OEM automotive applications



## VIP series sensors for engine/gearbox applications

Electromagnetic displacement sensors in the VIP series (wear-free, inductive and potentiometric) from Micro-Epsilon operate according to a patented measuring principle.

The combination of a flexible measuring principle and the innovation capacity of our engineers, enable us to find solutions for a diverse range of applications, which meet both the technical requirements as well as cost reduction.

Typical application areas for VIP series sensors are linear movements in engines and gearboxes. Single sensors as well as lowcost, compact quadruple systems can be installed directly in the gearbox.

Some application examples are:



Sensor in plastic housing for gearbox applications

### Valve lift

For valve gear without camshafts, the sensor records and regulates the position of the valve actuator. For example, the armature position on the actuator is recorded in electric actuators, while the piston position is measured for hydraulic actuators.

### Selector rods and selector levers

Due to the use of highly stable components, the sensor also operates reliably directly in the oil sump and records the position of the selector lever or selector rod.

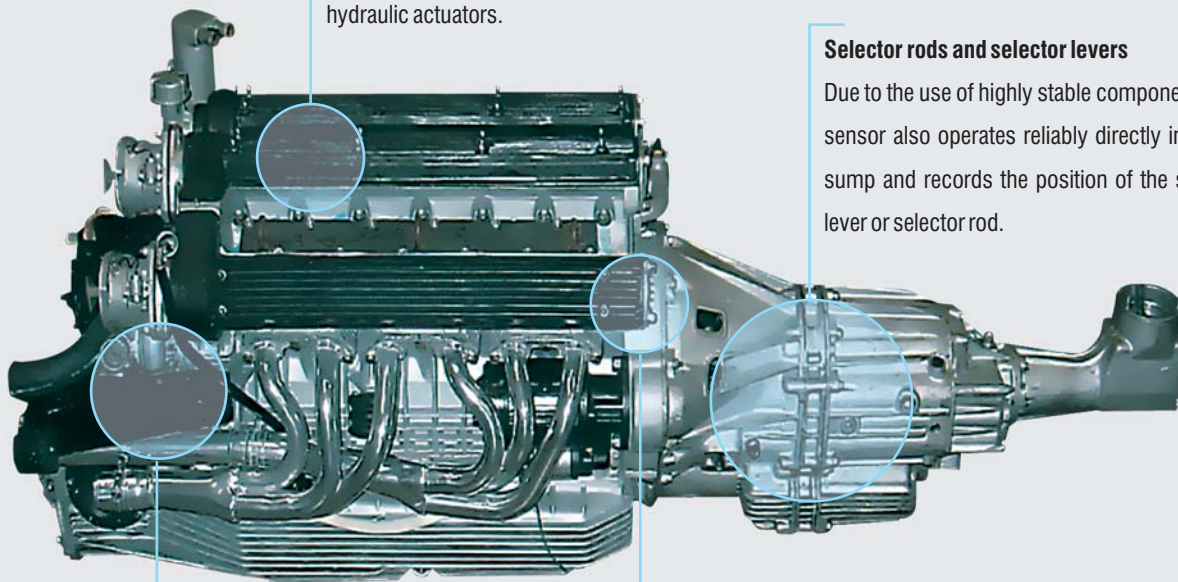

### Turbocharger actuator

The dynamics advantages of the sensor are particularly evident for pneumatic actuators (pressure or vacuum sensors). These are used, for example, on turbochargers and for gearbox applications in commercial vehicles.

### Clutch position

Proven applications include the clutch pedal whose position is measured in the clutch release bearing. The linear displacement signal is used for control and for wear monitoring.

## Benefits of the VIP series sensors

### Excellent resolution

One benefit of the measuring principle is the extremely high basic precision. The resolution is a genuine 0.1% and is therefore clearly above the precision class of comparable sensors. Thus, the constantly increasing requirements for positioning accuracy can now be satisfied.

### Inexpensive concept

The sensor design does not use expensive materials. A ring made of aluminium or copper is used as the target; the coil itself does not need any high permeable foils or cores. The basic requirement for lowcost, high volume sensor production is satisfied by dispensing with special magnetic materials and the use of lowcost ASIC electronics. In this way and by using state-of-the-art manufacturing processes such as Duroplast injection moulding, high quality sensors are produced at favourable costs.

### Sensor design without permanent magnet

One of the most important benefits of the VIP displacement sensors is that the measuring principle does not use any permanent magnets. The reason this is important is because there are serious drawbacks when using permanent magnets. Permanent magnets accumulate chippings, change their effect depending on the ambient temperature and change their characteristics with increasing service life. In contrast, VIP sensors are extremely stable under different temperatures and have long service lives.

### High dynamics

The VIP principle makes very fast reaction times possible for high speed processes (e.g. for pneumatic actuators). The cut-off frequency (-3 dB) is 1kHz and is therefore significantly higher than for comparable inductive sensors. High dynamic processes can also be controlled precisely in this way.

### Temperature range

The sensor layout with internal electronics is designed for continuous operation up to 125°C. With a corresponding temperature profile, peak temperatures up to 150°C can also be achieved.

If the sensor has to withstand temperatures above 150°C, a design with external electronics is recommended. This design permits temperature ranges up to 180°C.

### Technical data

Model	VIP
Measuring range	0 - 10 mm...0 - 200 mm
Linearity	< ±0.5 % FSO
Resolution	<0.1 % FSO
Accuracy	< ± 2 % FSO
Temperature range	-40 °C ... +125 °C (continuous operation); +150 °C top level temperature (short-time, with integral electronics, + 180 °C are possible without integral electronics)
Frequency response (-3 dB)	<1 kHz
Output	0.5 - 4.5 VDC radiometric, PWM (frequency <1kHz, profit range 10 % to 90 %, time constant ≤3 ms)
Power supply	+5 VDC (± 0.2 VDC)
Current consumption	< 20 mA
Protection class	IP 67

FSO = Full Scale Output

- Sensor design without permanent magnet
- Very compact design
- Easy adaptation for different targets
- High dynamics and resolution
- Inexpensive concept
- Extremely stable under different temperatures

### Compact sensor design

The favourable relationship between measuring range and sensor length is another decisive benefit of the VIP sensor. This results in a very compact design in comparison with other inductive displacement sensors. This space-saving design enables the installation of the sensor where space is restricted (e.g. on the engine, in the gearbox, on the clutch or in actuators).

# VIP series - measurement principle and application examples

## Measurement principle:

The electromagnetic sensors in the VIP series (wear-free, inductive and potentiometric) from Micro-Epsilon operate using a novel, patented measuring principle. A measurement coil (1) is wound on a coil former and has a number of voltage taps (2). As a measurement object a target (3) is used of electrically conductive or ferromagnetic material, the length of which corresponds to the distance between two taps on the measurement coil.

## Block diagram VIP series

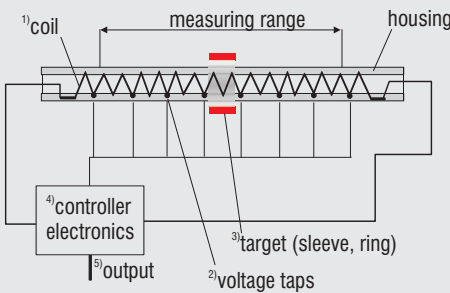

The measurement coil is supplied with two complementary alternating voltages from an oscillator. Depending on the position of the target, the impedance of the measure-

ment coil changes in the covered region. The tapped voltages are conditioned in an electronic evaluation unit (4), which produces a continuous signal on its output (5) that is proportional to the target position.

If the target is located, for example, in the middle of the measurement coil, the output signal corresponds to the reference voltage.

## VIP series design example

Depending on the application, there are numerous sensor models that can be adapted to specific measuring tasks by using different targets such as ring, core, air gap or corresponding combinations of these.

The main difference to LVDT sensors is that with the VIP series the target (6) is mounted parallel to the sensor (7). This highly efficient construction gives you innovative possibilities for sensor mounting. The figure shows an installation example, of how sensors in the VIP series can be mounted in

a similar method to side operated potentiometers (parallel mounting).

## Design example: Parallel mounting e.g. selector rods parallel mounting

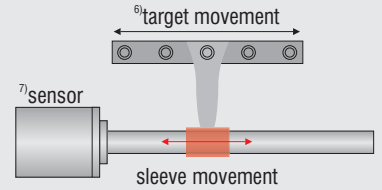

Similar to conventional LVDT sensors, the VIP series sensors can also be designed as a sensor sleeve. In contrast to the LVDT sensors, a clearly more favourable relationship of measuring range and sensor length is achieved. For example, a measuring range of 10mm can be recorded by a sensor with a total length of 19mm (valve lift measurement).

## Design example: Valve lift measurement e.g. actuator for valve lift

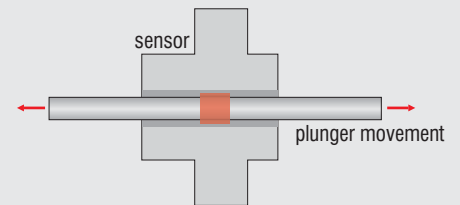

Compact sensor for valve stroke measurements

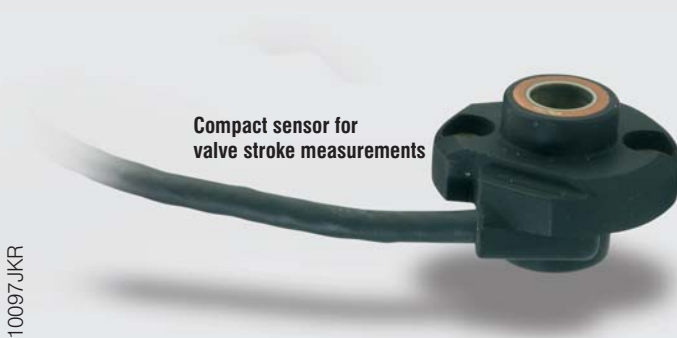

Modifications reserved / Y9761205-A010097JKR



**MICRO-EPSILON**

info@micro-epsilon.com  
www.micro-epsilon.com

info@micro-epsilon.co.uk  
www.micro-epsilon.co.uk

info@micro-epsilon.us  
www.micro-epsilon.us

