



Operating Instructions **optoNCDT 1220-IO**

ILD 1220-10-IO
ILD 1220-25-IO
ILD 1220-50-IO
ILD 1220-100-IO
ILD 1220-200-IO

ILD 1220-500-IO

Intelligent laser optical displacement measurement

MICRO-EPSILON
MESSTECHNIK
GmbH & Co. KG
Koenigbacher Str. 15

94496 Ortenburg / Germany

Tel. +49 (0) 8542 / 168-0
Fax +49 (0) 8542 / 168-90
e-mail info@micro-epsilon.com
www.micro-epsilon.com

Contents

1.	Safety	5
1.1	Symbols Used	5
1.2	Warnings	5
1.3	Notes on CE Marking	6
1.4	Notes on UKCA Marking	7
1.5	Intended Use	7
1.6	Proper Environment	7
2.	Laser Safety	8
3.	Functional Principle, Technical Data	10
3.1	Short Description	10
3.2	Advanced Surface Compensation	11
3.3	Technical Data	12
4.	Delivery	14
4.1	Unpacking, Included in Delivery	14
4.2	Return of packaging	14
4.3	Storage	14
4.4	Structure of the Serial Number	14
5.	Installation	15
5.1	Notes for Operation	15
5.1.1	Reflection Factor of the Target Surface	15
5.1.2	Error Influences	16
5.1.2.1	Light from other Sources	16
5.1.2.2	Color Differences	16
5.1.2.3	Temperature Influences	16
5.1.2.4	Mechanical Vibration	16
5.1.2.5	Movement Blurs	16
5.1.2.6	Surface Roughness	17
5.1.2.7	Angle Influences	18
5.1.3	Optimizing the Measuring Accuracy	19
5.2	Mounting, Dimensions	20

5.3	Indicator Elements at Sensor	22
5.4	Electrical Connections	23
5.4.1	Connection and Pin Assignment.....	23
5.4.2	Supply Voltage	24
5.4.3	Laser on.....	24
5.4.4	Sensor Cable.....	24
6.	Getting Ready for Operation.....	25
7.	IO-Link	26
7.1	Preliminary Remarks.....	26
7.2	Data Format	26
7.3	Object Directory.....	27
7.3.1	Standard Objects	27
7.3.1.1	Object 0x0000: Direct Parameter Page 1.....	27
7.3.1.2	Object 0x0002: System Command.....	28
7.3.1.3	Object 0x0003: Data Storage.....	29
7.3.1.4	Object 0x0013 ... 0x0028: IO-spezifisch	30
7.3.2	Manufacturer Specific Objects	32
7.3.3	Error Handling	33
7.4	System Settings.....	33
7.4.1	General.....	33
7.4.2	Keylock	33
8.	Digital Output Values.....	34
9.	Cleaning.....	35
10.	Disclaimer.....	36
11.	Service, Repair	36
12.	Decommissioning, Disposal	37
	Appendix.....	38
A 1	IODD Default Settings.....	38
A 2	Switching between IO-Link and Setup-Mode	39

1. Safety

Sensor operation assumes knowledge of the operating instructions.

1.1 Symbols Used

The following symbols are used in this operating instructions:



Indicates a hazardous situation which, if not avoided, may result in minor or moderate injury

NOTICE

Indicates a situation that may result in property damage if not avoided.



Indicates a user action.

i

Indicates a tip for users.

Measure

Indicates hardware or a software button/menu.

1.2 Warnings

Avoid unnecessary laser radiation to be exposed to the human body.

 Switch off the sensor for cleaning and maintenance.

 Switch off the sensor for system maintenance and repair if the sensor is integrated into a system.

Caution - use of controls or adjustments or performance of procedures other than those specified may cause harm.



Connect the power supply and the display/output device according to the safety regulations for electrical equipment.

> Risk of injury

> Damage to or destruction of the sensor

NOTICE

Avoid shocks and impacts to the sensor.
> Damage to or destruction of the sensor

Mount the sensor only to the existing holes on a flat surface. Clamps of any kind are not permitted.
> Damage to or destruction of the sensor

The supply voltage must not exceed the specified limits.
> Damage to or destruction of the sensor

Protect the sensor cable against damage. Attach the cable load-free, hold the cable after appr. 25 cm e.g. zip tie.
> Destruction of the sensor
> Failure of the measuring device

Avoid constant exposure of sensor to splashes of water.
> Damage to or destruction of the sensor

Avoid exposure of sensor to aggressive media (detergents, cooling emulsions).
> Damage to or destruction of the sensor

1.3 Notes on CE Marking

The following apply to the optoNCDT 1220-IO:

- EU Directive 2014/30/EU
- EU Directive 2011/65/EU

Products which carry the CE mark satisfy the requirements of the EU directives cited and the relevant applicable harmonized European standards (EN). The sensor is designed for use in industrial environments.

The EU Declaration of Conformity and the technical documentation are available to the responsible authorities according to the EU Directives.

1.4 Notes on UKCA Marking

The following apply to the optoNCDT 1220-IO:

- SI 2016 No. 1091:2016-11-16 The Electromagnetic Compatibility Regulations 2016
- SI 2012 No. 3032:2012-12-07 The Restriction of the Use of Certain Hazardous Substances in Electrical and Electronic Equipment Regulations 2012

Products which carry the UKCA mark satisfy the requirements of the directives cited and the relevant applicable standards. The sensor is designed for use in industrial environments.

The UKCA Declaration of Conformity and the technical documentation are available to the responsible authorities according to the UKCA Directives.

1.5 Intended Use

- The optoNCDT 1220-IO system is designed for use in industrial applications.
- It is used
 - for measuring displacement, distance, position and thickness
 - for in-process quality control and dimensional testing
- The sensor must only be operated within the limits specified in the technical data, see [Chap. 3.3](#).
- The sensor must be used in such a way that no persons are endangered or machines and other material goods are damaged in the event of malfunction or total failure of the controller.
- Take additional precautions for safety and damage prevention in case of safety-related applications.

1.6 Proper Environment

- Protection class: IP67 (applies only when the sensor cable is plugged in)

Lenses are excluded from protection class. Contamination of the lenses leads to impairment or failure of the function.

- Temperature range:
 - Operation: 0 °C ... +50 °C (+32 ... +104 °F)
 - Storage: -20 °C ... +70 °C (-4 ... +158 °F)
- Humidity: 5 ... 95 % RH (non-condensing)
- Ambient pressure: Atmospheric pressure

I The protection class is limited to water (no penetrating liquids, detergents or similar aggressive media).

2. Laser Safety

The ILD1220-IO sensors operate with a semiconductor laser with a wavelength of 670 nm (visible/red). The sensors fall within laser class 2. The laser is operated on a pulsed mode, the maximum optical power is ≤ 1 mW. The pulse frequency depends on the adjusted measuring rate (0.25 ... 2 kHz). The pulse duration of the peaks is regulated depending on the measuring rate and reflectivity of the target and can be 0.3 ... 3999.6 μ s.



Laser radiation. Irritation or injury of the eyes possible. Close your eyes or immediately turn away if the laser beam hits the eye.

- Observe the national laser protection regulations.

Although the laser output is low, directly looking into the laser beam must be avoided. Close your eyes or immediately turn away if the laser beam hits the eye.

Lasers of Class 2 are not subject to notification and a laser protection officer is not required.

The following warning labels are attached to the sensor cable.



Fig. 1 Laser labels on the sensor cable



Fig. 2 Laser warning sign on the sensor housing

During operation of the sensor the pertinent regulations according to IEC 60825-1 on „Safety of laser products“ must be fully observed at all times. The sensor complies with all applicable laws for the manufacturer of laser devices.

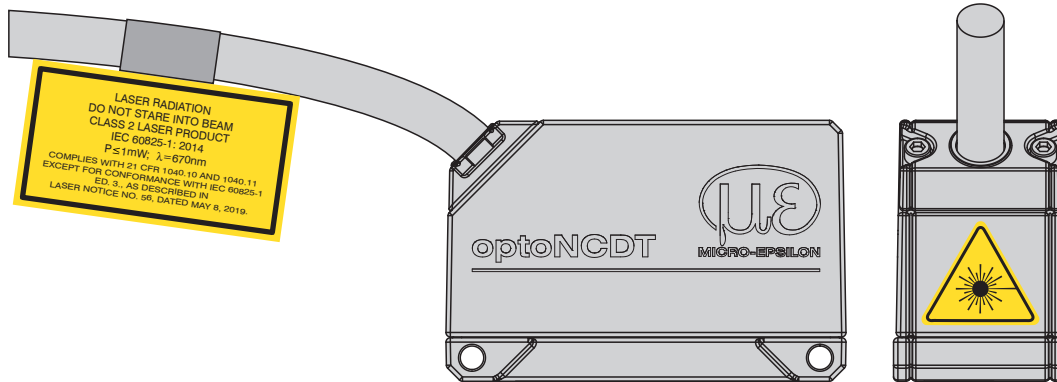

Fig. 3 Sensor cable and sensor with laser sign, ILD 1220-IO

i If both warning labels are covered over when the unit is installed, the user must ensure that supplementary labels are applied.

Operation of the laser is indicated visually by the LED on the sensor, see [Chap. 5.3](#).

The housing of the optical sensors may only be opened by the manufacturer, see [Chap. 10](#).

For repair and service purposes, the sensors must always be sent to the manufacturer.

Please observe national regulations, e. g., Laser Notice No. 50 for the USA.

3. Functional Principle, Technical Data

3.1 Short Description

The optoNCDT 1220-IO uses the principle of optical triangulation, that is, a visible, modulated point of light is projected onto the target surface.

The diffuse part of the reflection of this point of light is displayed depending on distance on a position-resolving element (CMOS) by an receiver optic which is arranged to the optical axis of the laser beam in a defined angle.

A signal processor in the sensor calculates the distance of the point of light on the measuring object to the sensor by means of the output signal of the CMOS elements. The distance value is linearized and output by means of the IO interface.

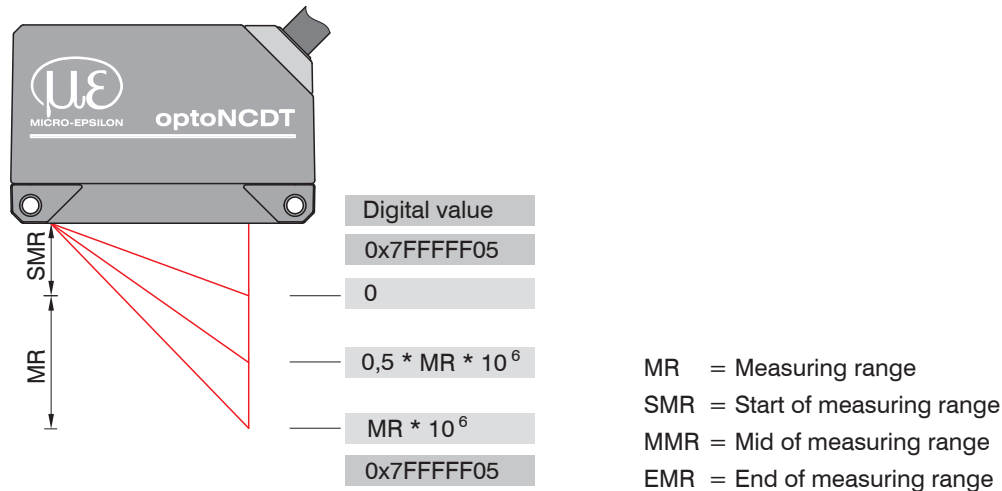

Fig. 4 Definition of terms

1) For distance values without zero setting or mastering only, values in nanometer

3.2 Advanced Surface Compensation

The sensor is equipped with an intelligent surface control feature. New algorithms generate stable measurement results even on demanding surfaces where changing reflections occur. Also small objects can be detected reliably thanks to the small measuring spot.

3.3 Technical Data

Model	ILD1220-10-IO	ILD1220-25-IO	ILD1220-50-IO	ILD1220-100-IO	ILD1220-200-IO	ILD1220-500-IO	
Measuring range	10 mm	25 mm	50 mm	100 mm	200 mm	500 mm	
Start of measuring range	20 mm	25 mm	35 mm	50 mm	60 mm	100 mm	
Mid of measuring range	25 mm	37.5 mm	60 mm	100 mm	160 mm	350 mm	
End of measuring range	30 mm	50 mm	85 mm	150 mm	260 mm	600 mm	
Measuring rate ⁽¹⁾	4 adjustable stages: 2 kHz / 1 kHz / 0.5 kHz / 0.25 kHz						
Linearity ⁽²⁾	< ±10 μm	< ±25 μm	< ±50 μm	< ±100 μm	< ±200 μm	< ±750 μm ... 1500 μm	
	< ±0.10 % FSO					< ±0.15 % ... 0.30 % FSO	
Repeatability ⁽³⁾	1 μm	2.5 μm	5 μm	10 μm	20 μm	50 μm	
Temperature stability ⁽⁴⁾	±0.015 % FSO / K			±0.01 % FSO / K			
Light spot diameter ⁽⁵⁾	SMR	100 x 130 μm	200 x 260 μm	250 x 340 μm	710 x 910 μm	710 x 910 μm	710 x 910 μm
	MMR	45 x 50 μm	55 x 60 μm	80 x 95 μm			
	EMR	160 x 200 μm	260 x 330 μm	300 x 380 μm	710 x 910 μm	710 x 910 μm	710 x 910 μm
	smallest Ø	45 x 40 μm at 24 mm	55 x 60 μm at 30 mm	75 x 85 μm at 42 mm			
Light source	Semiconductor laser < 1 mW, 670 nm (red)						
Laser class	Class 2 in accordance with IEC 60825-1: 2014						
Permissible ambient light ⁽⁶⁾	20,000 lx				7,500 lx		

(1) Factory setting 1 kHz, modifying the factory setting requires the IF2001/USB converter (see accessories)

(2) FSO = Full Scale Output; the specified data apply to white, diffuse reflecting surfaces (Micro-Epsilon reference ceramic for ILD sensors)

(3) Measuring rate 1 kHz, median 9

(4) mnThe specified value is only achieved by mounting on a metallic sensor holder. Good heat dissipation from the sensor to the holder must be ensured.

(5) ±10 %; SMR = Start of measuring range; MMR = Mid of measuring range; EMR = End of measuring range

(6) Illuminant: light bulb

Model	ILD1220-10-IO	ILD1220-25-IO	ILD1220-50-IO	ILD1220-100-IO	ILD1220-200-IO	ILD1220-500-IO
Supply voltage	24V (11,2 ... 30V) DC, P < 2W					
Power consumption	< 2 W (24 V)					
Signal input	1 x HTL laser on/off; 1 x HTL multifunction input: trigger in, zero setting, teach					
Digital interface	RS422 (16 bit)					
Analog Output	4 ... 20 mA (16 bit, freely scalable within the measuring range)					
Switching output	1 x error output: npn, pnp, push pull, push-pull negated					
Connection	integrated cable 2 m, open ends, minimum bending radius 30 mm (fixed installation)					
Mounting	Screw connection via two mounting holes					
Temperature range	Storage	-20 ... +70 °C (non-condensing)				
	Operation	0 ... +50 °C (non-condensing)				
Shock (DIN EN 60068-2-27)	15 g / 6 ms in 3 axes, 1000 shocks each					
Vibration (DIN EN 60068-2-6)	20 g / 20 ... 500 Hz in 3 axes, 2 directions and 10 cycles each					
Protection class (DIN EN 60529)	IP67					
Material	Aluminum housing					
Weight	approx. 40 g (without cable), approx. 120 g (incl. cable)					
Control and indicator elements ⁽⁷⁾	Select button: zero, teach, factory settings; web interface for setup; 2 x color LEDs for power / status					

(7) Access to web interface requires connection to PC via IF2001/USB (see accessories)

4. Delivery

4.1 Unpacking, Included in Delivery

- 1 Sensor ILD 1220-IO-Link
- 1 Assembly instruction
- Accessories (2 pieces screw M2 and 2 pieces washer)

- ▶ Carefully remove the components of the measuring system from the packaging and ensure that the goods are forwarded in such a way that no damage can occur.
- ▶ Check the delivery for completeness and shipping damage immediately after unpacking.
- ▶ If there is damage or parts are missing, immediately contact the manufacturer or supplier.

4.2 Return of packaging

Micro-Epsilon Messtechnik GmbH & Co. KG offers customers the opportunity to return the packaging of products purchased from Micro-Epsilon by prior arrangement so that it can be reused or recycled.

To arrange the return of packaging, for questions about the costs and / or the exact return procedure, please contact us directly at info@micro-epsilon.com

4.3 Storage

Temperature range storage: -20 ... +70 °C (-4 °F ... +158 °F)

Humidity: 5 ... 95 % RH (non-condensing)

4.4 Structure of the Serial Number

Sensors in a new design have an extended measuring rate, a higher resolution D/A converter and an improved protection class, see [Chap. 3](#). They can be recognized by the serial number with the following structure:

- 10xxxxxx = ILD1220-10-IO, ILD1220-25-IO, ILD1220-50-IO
- 40xxxxxx = ILD1220-100-IO, ILD1220-200-IO, ILD1220-500-IO

Serial numbers for sensors with the old design can be recognized by the following structure:
JJMMxxxx (J = year, M = month)

5. Installation

5.1 Notes for Operation

5.1.1 Reflection Factor of the Target Surface

In principle the sensor evaluates the diffuse part of the reflected laser light.

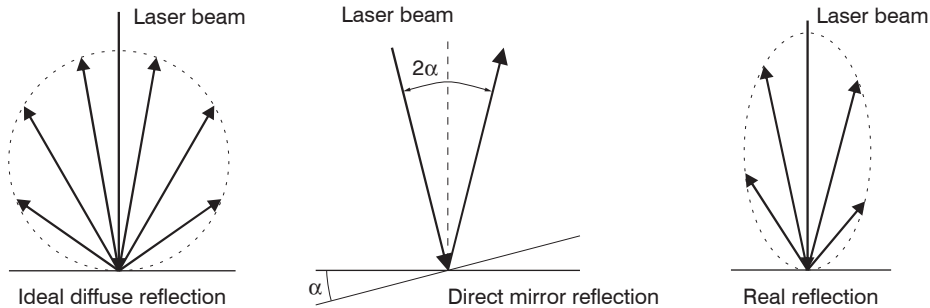

Fig. 5 Reflection factor of the target surface

A statement concerning a minimum reflectance is difficult to make because even a small diffuse fraction can be evaluated from highly reflecting surfaces. This is done by determining the intensity of the diffuse reflection from the CMOS signal in real time and subsequent compensation, see [Chap. 3.2](#). Dark or shiny objects being measured, e.g. black rubber, may require longer exposure times. The exposure time is dependent on the measuring rate and can only be increased by reducing the sensor's measuring rate.

5.1.2 Error Influences

5.1.2.1 Light from other Sources

Thanks to their integrated optical interference filters the optoNCDT 1220-IO sensors offer outstanding performance in suppressing light from other sources. However, this does not preclude the possibility of interference from other light sources if the objects being measured are shiny and if lower measuring rates are selected. Should this be the case it is recommended to use suitable shields to screen the other light sources. This applies in particular to measurement work performed in close proximity to welding equipment.

5.1.2.2 Color Differences

Because of intensity compensation, color difference of targets affect the measuring result only slightly. However, such color differences are often combined with different penetration depths of the laser light into the material. Different penetration depths then result in apparent changes of the measuring spot size. Therefore color differences in combination with changes of penetration depth may lead to measuring errors.

5.1.2.3 Temperature Influences

When the sensor is commissioned a warm-up time of at least 20 minutes is required to achieve uniform temperature distribution in the sensor. If measurement is performed in the micron accuracy range, the effect of temperature fluctuations on the sensor holder must be considered. Due to the damping effect of the heat capacity of the sensor, sudden temperature changes are only measured with delay.

5.1.2.4 Mechanical Vibration

If the sensor is to be used for resolutions in the μm to sub- μm range, special care must be taken to ensure stable and vibration-free mounting of sensor and target.

5.1.2.5 Movement Blurs

If the objects being measured are fast moving and the measuring rate is low, it is possible that movement blurs may result. Always select a high measuring rate for high-speed operations, therefore, in order to prevent errors.

5.1.2.6 Surface Roughness

Laser-optical sensors detect the surface using an extremely small laser spot. They also track slight surface unevenness. In contrast, a tactile, mechanical measurement, e.g. using a caliper, detects a much larger area of the measurement object. In case of traversing measurements, surface roughnesses of $5\ \mu\text{m}$ and more lead to an apparent distance change.

Suitable parameters for the averaging number may improve the comparability of optical and mechanical measurements.

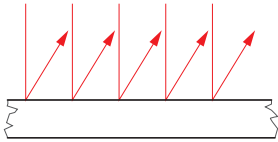

Ceramic reference surface

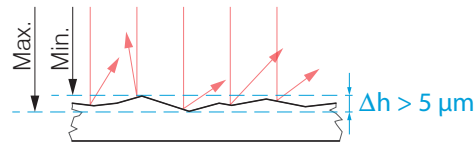

Structured surface

Recommendation for parameter choice:

The averaging number should be selected in such a way that a surface area the size of which is comparable to those with mechanical measurements is averaged.

5.1.2.7 Angle Influences

Tilt angles of the target in diffuse reflection both around the X and the Y axis of less than 5° only have a disturbing effect with surfaces which are highly reflecting.

These influences have to be explicitly considered when scanning profiled surfaces. Basically the angle behavior of triangulation is liable to the reflectivity of the measuring object surface.

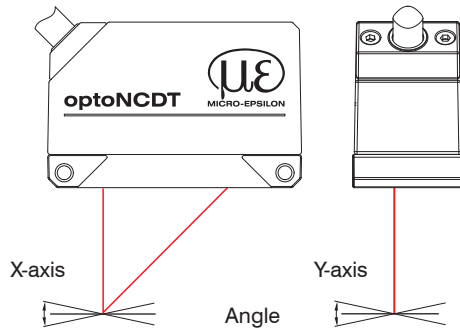
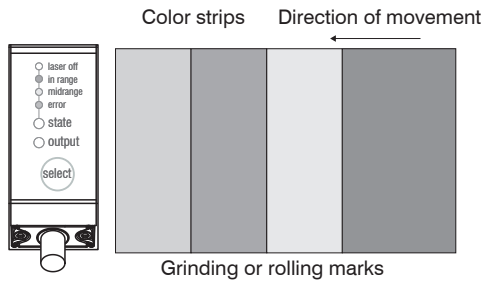

Fig. 6 Measurement errors through tilting with diffuse reflection

5.1.3 Optimizing the Measuring Accuracy



In case of rolled or polished metals that are moved past the sensor the sensor plane must be arranged in the direction of the rolling or grinding marks. The same arrangement must be used for color strips.

Fig. 7 Sensor arrangement in case of ground or striped surfaces

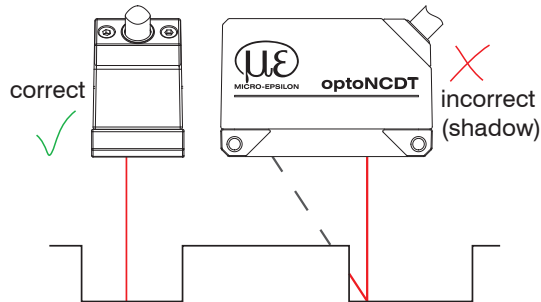

In case of bore holes, blind holes and edges in the surface of moving targets the sensor must be arranged in such a way that the edges do not obscure the laser spot.

Fig. 8 Sensor arrangement for holes and ridges

5.2 Mounting, Dimensions

The optoNCDT 1220-IO sensor is an optical system for measurements with micrometer accuracy. The laser beam must be directed perpendicularly onto the surface of the target. In case of misalignment it is possible that the measurement results will not always be accurate.

i Make sure it is handled carefully when installing and operating.

▶ Mount the sensor by means of 2 screws type M3 or by means of through bores for M2 with the screws from the accessories.

Bolt connection					Direct fastening			
								
Through length	Screw depth	Screw	Washer	Torque	Screw depth		Screw	Torque
	Minimum	ISO 4762-A2	ISO 7089-A2	$\mu = 0.12$	Minimum	Maximum	ISO 4762-A2	$\mu = 0.12$
mm	mm	2 pieces		Nm	mm	mm	2 pieces	Nm
20	5.0	M2 x 25	A2.2	0.5	4.8	8.5	M3	1.0

Fig. 9 Mounting conditions

The bearing surfaces surrounding the through-holes (mounting-holes) are slightly raised.

i Mount the sensor only to the existing holes on a flat surface. Clamps of any kind are not permitted. Do not exceed torques.

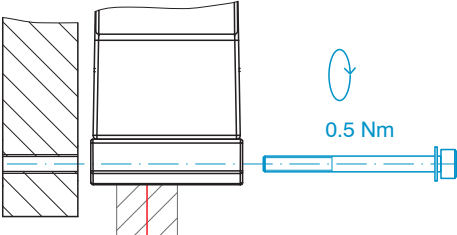
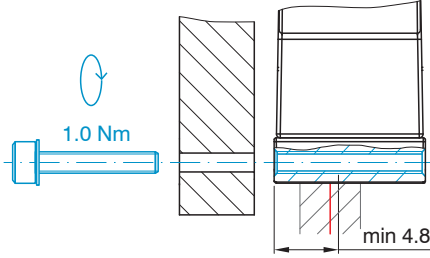
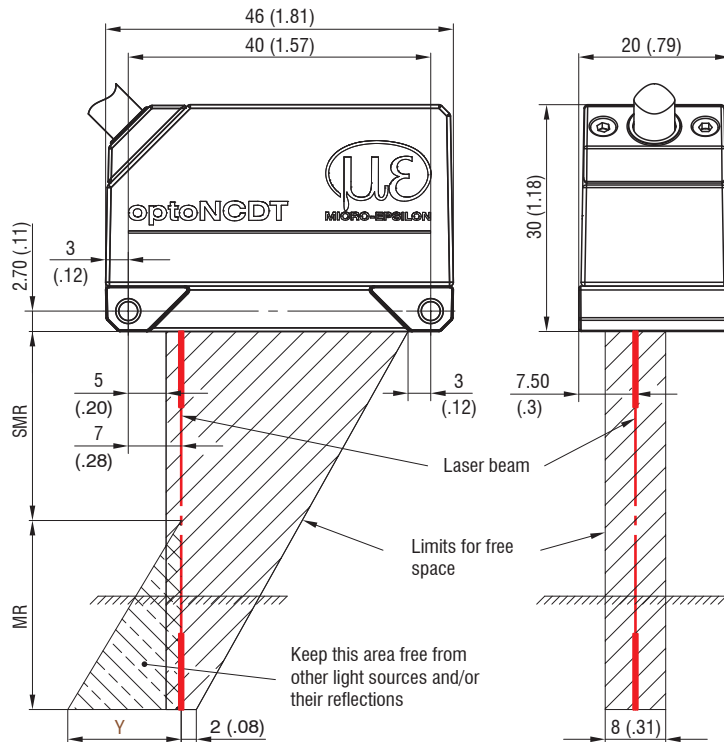

Fig. 10 Dimensional drawing and free space for optics and optical free space

ILD 1220-		10-IO	25-IO	50-IO	100-IO	200-IO	500-IO
MR	mm	10	25	50	100	200	500
SMR	mm	20	25	35	50	60	100
EMR	mm	30	50	85	150	260	600
Y	mm	10	21	28	46	70	190

The indicated free space in the reception area has to be kept clear from foreign objects and extraneous light of other laser sensors at least until the end of measuring range.

- MR = Measuring range
- SMR = Start of measuring range
- MMR = Mid of measuring range
- EMR = End of measuring range
- FSO = Full scale output

5.3 Indicator Elements at Sensor

LED State	Meaning
green	Measuring object within sensor range
yellow	Mid range
red	Error - e.g. Poor target or out of range
off	Laser off
LED Output	Meaning
orange	IO-Link measurement value output
off	Sensor off, no supply

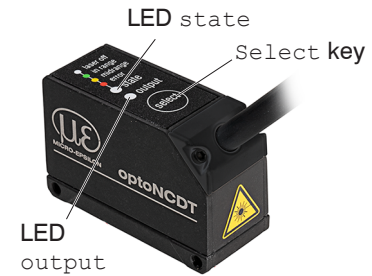

The programmable touch key `select` calls up the functions `Reset`, `Teaching` or `zeroing`. By factory default this key is only active for the first 5 minutes after power up. After that it will be automatically locked.

5.4 Electrical Connections

5.4.1 Connection and Pin Assignment

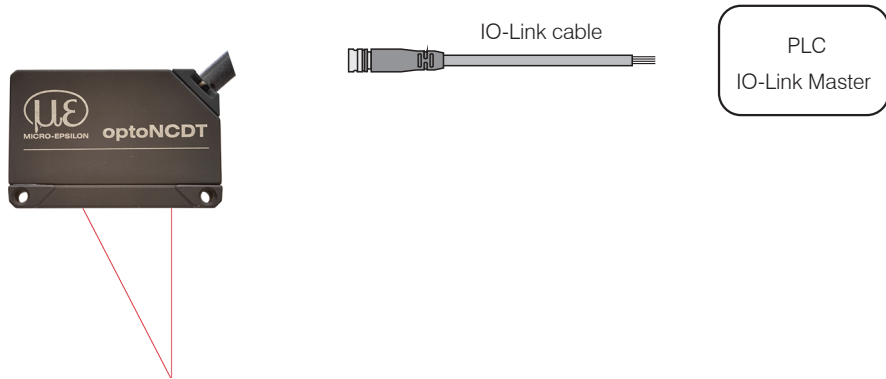

Fig. 11 Connection to a PLC

Pin 4-pin M12 male sensor connector, A-coded	Description		Specification
	Pin	Signal	
1	V ₊	Supply voltage	11,2 ... 30 VDC, typ. 24 VDC, P < 2 W
2	n.c.		
4	C/Q IO-Link		
3	GND	Supply ground	Supply and signal ground

View: Pin side male sensor connector

The laser light source in the sensor is activated when the supply voltage is applied. You can switch off the laser light source via software.

5.4.2 Supply Voltage

Nominal value: 24 VDC (11,2 ... 30 V, $P < 2 \text{ W}$).

Die Versorgung des Sensors erfolgt über den IO-Link Master.

5.4.3 Laser on

The laser light source in the sensor is activated when the supply voltage is applied. You can switch off the laser light source via software.

5.4.4 Sensor Cable

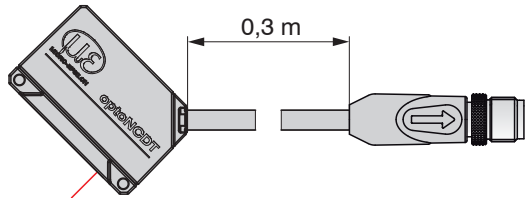

Fig. 12 Sensor with pigtail

➤ Never fall below the bending radius for the sensor cable of 30 mm (fixed) or 60 mm (dynamic).

i

The fixed connected sensor cable (pigtail) is not cable carriers suitable.

➤ Avoid excessive pulling to the cables. Provide strain relieves near the connectors when cables $> 5 \text{ m}$ are vertically free hanging.

➤ Never lay signal leads next to or together with power cables or pulse-loaded cables (e.g. for drive units and solenoid valves) in a bundle or in cable ducts. Always use separate ducts.

6. Getting Ready for Operation

➡ Install and assemble the optoNCDT 1220-IO in accordance with the instructions set out, see [Chap. 5](#).

➡ Connect the sensor with the IO-Link master.

Once the supply voltage has been switched on the sensor runs through an initialization sequence. This is indicated by the momentary activation of all the LEDs. Once initialization has been completed, the sensor transmits a „->“ via the IO interface. The initialization takes up to 10 seconds. Within this period, the sensor executes the `Reset` command through the key `Select` only.

To be able to produce reproducible measurements the sensor typically requires a start-up time of 20 minutes.

If the LED `output` is off, this means that there is no supply voltage.

If the LED `state` is off, this means that the laser light source has been switched off.

7. IO-Link

7.1 Preliminary Remarks

You can program the optoNCDT 1220-IO simultaneously in two different ways:

- via IO-Link Master and PLC or
- via USB IO-Link Master.

The sensor interface corresponds to version 1.1; the data rate is 230.4 kbit/s (COM3).

7.2 Data Format

The sensor sends data in big endian format.

If the PLC uses the big-endian format, the byte order must be swapped.

AllenBradley	Big-Endian
BECKHOFF	Big-Endian
Festo	Little-Endian
Omron	Big-Endian
SIEMENS S7-300	Big-Endian
SIEMENS S7-1200/150	Little-Endian

Fig. 13 Data format, examples of some manufacturers

7.3 Object Directory

7.3.1 Standard Objects

7.3.1.1 Object 0x0000: Direct Parameter Page 1

Index	Subindices	IO-Link designation	Type	Access	Value / Default Value	
0x0000 RecordT	0x00	MasterCommand		W	0x00 to 0x59 Reserved 0x5A Fallback 0x5B to 0x94 Reserved 0x95 MasterIdent 0x96 DeviceIdent	0x97 DeviceStartup 0x98 ProcessDataOutputOperate 0x99 DeviceOperate 0x9A DevicePreoperate 0x9B to 0xFF Reserved
	0x01	MasterCycleTime		R/W		
	0x02	MinCycleTime	UINT8	R	0x05 -> 500μs	
	0x03	M-sequence Capability	UINT8	R	0x29 -> 41	
	0x04	RevisionID	UINT8	R/W	0x11 -> Revision 1.1	
	0x05	ProcessDataIn	UINT8	R	0x83 -> 4 Bytes, no SIO	
	0x06	ProcessDataOut	UINT8	R	0x00	
	0x07	VendorID 1 (MSB)	UINT16	R	0x04, 0x26 -> 1062	
	0x08	VendorID 2 (LSB)				
	0x09	DeviceID 1 (Octet 2, MSB)	UINT32	R/W	MB 010 (7A , 5C, 40) -> 8019008	
	0x0A	DeviceID 2 (Octet 1)			MB 025 (7A , 5C, 41) -> 8019009	
	0x0B	DeviceID 3 (Octet 0, LSB)			MB 050 (7A , 5C, 42) -> 8019010	
						MB 100 (7A , 5C, 43) -> 8019011
					MB 200 (7A , 5C, 44) -> 8019012	
					MB 500 (7A , 5C, 45) -> 8019013	
0x0F	SystemCommand			W	see SystemCommand 0x0002	

7.3.1.2 Object 0x0002: System Command

Index	Subindices	IO-Link designation	Manufacturer-specific designation	Type	Access	Value / Default Value
0x0002 UIntegerT	0x00	Reserved		UINT8		send subindice in data byte
	0x01	ParamUploadStart ¹		UINT8		send subindice in data byte
	0x02	ParamUploadEnd		UINT8		send subindice in data byte
	0x03	ParamDownloadStart		UINT8		send subindice in data byte
	0x04	ParamDownloadEnd		UINT8		send subindice in data byte
	0x05	ParamDownloadStore		UINT8		send subindice in data byte
	0x06	ParamBreak		UINT8		send subindice in data byte
	0x80	Device reset		UINT8	W	send subindice in data byte
	0x81	Application reset		UINT8	W	send subindice in data byte
	0x82	Restore factory settings		UINT8	W	send subindice in data byte
	0x83	Back-to-box		UINT8	W	send subindice in data byte
	0xA1		Meassettings Read Standard	UINT8	W	send subindice in data byte
	0xAA		Preset Mode STATIC	UINT8	W	send subindice in data byte
	0xAB		Preset Mode BALANCED	UINT8	W	send subindice in data byte
	0xAC		Preset Mode DYNAMIC	UINT8	W	send subindice in data byte
	0xAD		Preset Mode NOAVERAGING	UINT8	W	send subindice in data byte
	0xB4		Meassettings Read User_Setting_1	UINT8	W	send subindice in data byte
	0xBE		Meassettings Store User_Setting_1	UINT8	W	send subindice in data byte
	0xC8		Meassettings Delete User_Setting_1	UINT8	W	send subindice in data byte

1) For BackUp / Restore via Data Storage: should not be used alone.

7.3.1.3 Object 0x0003: Data Storage

Index	Subindices	IO-Link designation	Type	Access	Size
0x0003 RecordT	0x01	DS_Command	UINT8	R/W	1
	0x02	State_Property	UINT8	R	1
	0x03	Data_Storage_Size	UINT32	R	4
	0x04	Parameter_Checksum	UINT32	R	4
	0x05	Index_List	OCTETSTRING	R	variable

7.3.1.4 Object 0x0013 ... 0x0028: IO-spezifisch

Index	Subindices	IO-Link designation	Type	Access	Value / Default Value	Size
0x000D		ProfileCharacteristic subindices access	Array of UINT16	RO		4
0x000E		PDInputDescriptor	Array of OCTETSTRING	RO		4
0x000F		PDOOutputDescriptor	Array of OCTETSTRING	RO		4
0x0010	0x00	Vendor Name	STRING	RO	MICRO-EPSILON MESSTECHNIK GmbH & Co. KG	40
0x0011	0x00	Vendor Text	STRING	RO	More Precision	15
0x0012	0x00	Product Name	STRING	RO	ILD1220-001-010-IO (MB 010) ILD1220-001-025-IO (MB 025) ILD1220-001-050-IO (MB 050) ILD1220-001-100-IO (MB 100) ILD1220-001-200-IO (MB 200) ILD1220-001-500-IO (MB 500)	34
0x0013	0x00	Product ID	STRING	RO	4120400-001-20 (MB 010) 4120401-001-20 (MB 025) 4120402-001-20 (MB 050) 4120403-001-20 (MB 100) 4120404-001-20 (MB 200) 4120405-001-20 (MB 500)	38
0x0014	0x00	Product Text	STRING	RO	Laser distance sensor for industrial applications	50
0x0015	0x00	Serial Number	STRING	RO	Serial: aus GETINFO	16
0x0016	0x00	Hardware Rev.	STRING	RO	0x04C4010214	13

Index	Subindices	IO-Link designation	Type	Access	Value / Default Value	Size
0x0017	0x00	Firmware Rev.	STRING	RO	Firmware version	21
0x0018	0x00	Application Specific Tag	STRING	R/W		32
0x0019	0x00	FunctionTag		R/W		32
0x001A	0x00	LocationTag		R/W		32
0x0020	0x00	ErrorCount	UINT	RO		2
0x0024	0x00	DeviceStaus	UINT	RO		1
0x0025	0x00	DetailedDeviceStatus	Array of OCTETSTRING	RO		variable
0x0028	0x00	ProcessDataInput	UINT32	RO	Last valid measurement in nm	1

7.3.2 Manufacturer Specific Objects

Index	Subindices	Designation	Type	Access	Value / Default Value	Size
0x0044	0x00	MEASRATE ¹	uint_16	R/W	250=250 500=500 1000=1000 2000=2000	2
0x0045	0x00	LASERPOW	uint_8	R/W	0=OFF 1=FULL 2=REDUCED 3=MEDIUM	1
0x0046	0x00	OUTHOLD Type	uint_8	R/W	0=NONE 1=VALUE 2=INFINITE	1
0x0047	0x00	OUTHOLD Value	uint_16	R/W	0 ... 1024	2
0x0048	0x00	KEYFUNC	uint_8	R/W	0=NONE 1=MASTERING	1
0x004A	0x00	MASTERMV NONE	uint_8	R/W	0=NONE 1=ACTIVE	1
0x004B	0x00	MASTERMV MASTER	float	R/W	0 up to 2 * MR	4
0x00FA	0x00	MEASSETTINGS LIST	string	RO		232
0x00FC	0x00	MEASSETTINGS CURRENT	string	RO		32
0x00FD	0x00	MEASSETTINGS PRESETLIST	string	RO		232
0x00FE	0x00	current_setting	uint_8	RO	0=Customized 1=Preset 2=User_Setting	1

1) With a maximum measuring rate of 1 kHz the CMOS element is exposed 1000 times per second. The lower the measuring rate, the higher maximum exposure time. The measuring rate can be adjusted is four stages.

7.3.3 Error Handling

The OUTHOLD Type and OUTHOLD Value objects control the behavior of the output in the event of an error, see [Chap. 7.3.2](#).

7.4 System Settings

7.4.1 General

After programming, save all settings permanently to a parameter set so that they will be available again the next time you switch on the sensor.

7.4.2 Keylock

The function keylock for the key `Select`, see [Chap. 5.3](#) prevents unauthorized / unintended performing of the key functions.

The key lock is automatically activated after a reset/power cycle after 5 minutes.

8. Digital Output Values

Signal	Minimum	Maximum	Scaling	Unit
Distance	0x80000000	0x7FFFFFF0	Value	nm

0x7FFFFFF4 no peak available

0x7FFFFFF5 peak before the measurement range (MR)

0x7FFFFFF6 peak behind the measurement range (MR)

9. Cleaning

Cleaning of the protective screens is recommended periodically.

Avoid unnecessary laser radiation to be exposed to the human body.

 Switch off the sensor for cleaning and maintenance.

Dry Cleaning

Therefore an optics anti-static brush is suitable or bleeding the screen with dehumidified, clean and oil-free compressed air.

Wet Cleaning

For cleaning the protective screen use a clean, soft, lint-free cloth or lens cleaning paper with pure alcohol (isopropyl).

Never use standard glass cleaner or other cleaning agents.

10. Disclaimer

All components of the device have been checked and tested for functionality in the factory. However, should any defects occur despite careful quality control, these shall be reported immediately to MICRO-EPSILON or to your distributor / retailer.

MICRO-EPSILON undertakes no liability whatsoever for damage, loss or costs caused by or related in any way to the product, in particular consequential damage, e.g., due to

- non-observance of these instructions/this manual,
- improper use or improper handling (in particular due to improper installation, commissioning, operation and maintenance) of the product,
- repairs or modifications by third parties,
- the use of force or other handling by unqualified persons.

This limitation of liability also applies to defects resulting from normal wear and tear (e.g., to wearing parts) and in the event of non-compliance with the specified maintenance intervals (if applicable).

MICRO-EPSILON is exclusively responsible for repairs. It is not permitted to make unauthorized structural and / or technical modifications or alterations to the product. In the interest of further development, MICRO-EPSILON reserves the right to modify the design.

In addition, the General Terms of Business of MICRO-EPSILON shall apply, which can be accessed under Legal details | Micro-Epsilon <https://www.micro-epsilon.com/impressum/>.

11. Service, Repair

If the sensor or sensor cable is defective:

- Please send us the affected parts for repair or exchange.

If the cause of a fault cannot be clearly identified, please send the entire measuring system to:

MICRO-EPSILON MESSTECHNIK
GmbH & Co. KG
Koenigbacher Str. 15
94496 Ortenburg / Germany

Tel. +49 (0) 8542 / 168-0
Fax +49 (0) 8542 / 168-90
info@micro-epsilon.com
www.micro-epsilon.com

12. Decommissioning, Disposal

In order to avoid the release of environmentally harmful substances and to ensure the reuse of valuable raw materials, we draw your attention to the following regulations and obligations:

- Remove all cables from the sensor and/or controller.
- Dispose of the sensor and/or the controller, its components and accessories, as well as the packaging materials in compliance with the applicable country-specific waste treatment and disposal regulations of the region of use.
- You are obliged to comply with all relevant national laws and regulations.

For Germany / the EU, the following (disposal) instructions apply in particular:

- Waste equipment marked with a crossed garbage can must not be disposed of with normal industrial waste (e.g. residual waste can or the yellow recycling bin) and must be disposed of separately. This avoids hazards to the environment due to incorrect disposal and ensures proper recycling of the old appliances.
- A list of national laws and contacts in the EU member states can be found at https://environment.ec.europa.eu/topics/waste-and-recycling/waste-electrical-and-electronic-equipment-weee_en. Here you can inform yourself about the respective national collection and return points.
- Old devices can also be returned for disposal to MICRO-EPSILON at the address given in the imprint at <https://www.micro-epsilon.de/impressum/>.
- We would like to point out that you are responsible for deleting the measurement-specific and personal data on the old devices to be disposed of.
- Under the registration number WEEE-Reg.-Nr. DE28605721, we are registered at the foundation Elektro-Altgeräte Register, Nordostpark 72, 90411 Nuremberg, as a manufacturer of electrical and/or electronic equipment.



Appendix

A 1 IODD Default Settings

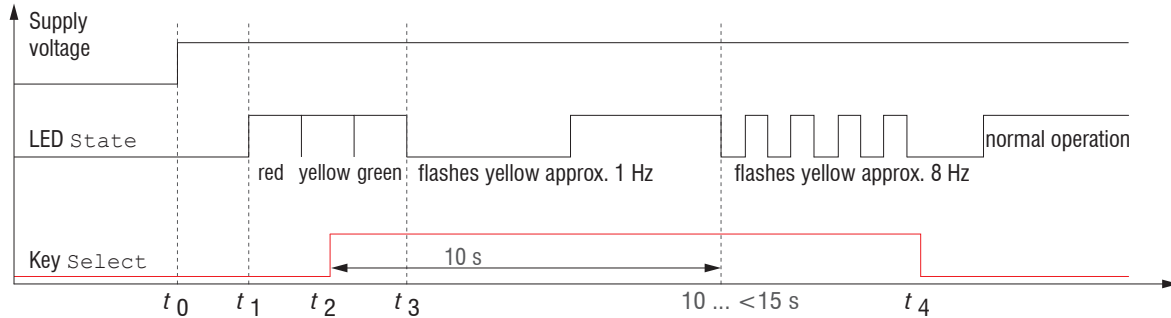

Fig. 14 Flow chart to restore factory setting

t_0 : power supply is on

$t_1 \dots t_3$: both LEDs signalize the start sequence (red-yellow-green for 1 sec. each)

t_2 : key is pressed during start sequence ($t_1 \dots t_3$)

t_4 : key is released while the LED State is flashing yellow

$\Delta t = t_4 - t_2$; Δt (key press period) must be at least 10 sec., max. 15 sec.

A 2 Switching between IO-Link and Setup-Mode

The sensor starts in the last stored operating mode. Factory setting is IO-Link. The Setup mode serves as an update mode if problems occur in IO-Link mode. The range of functions in setup mode is very limited.

➤ Press and hold the Select button on the sensor before switching on the power supply on the sensor. Release the button again as soon as the State LED flashes yellow. Press the button again for approx. 10 to 15 seconds until the State LED flashes red.

Within the time $t_2 \dots t_3$, red flashing starts with 8 Hz after 10 seconds. The key must be released again after 15 seconds at the latest. When the Select button is released at the latest at time t_3 , the yellow State LED starts flashing at 8 Hz in the colors red, green and yellow for 3 seconds each.

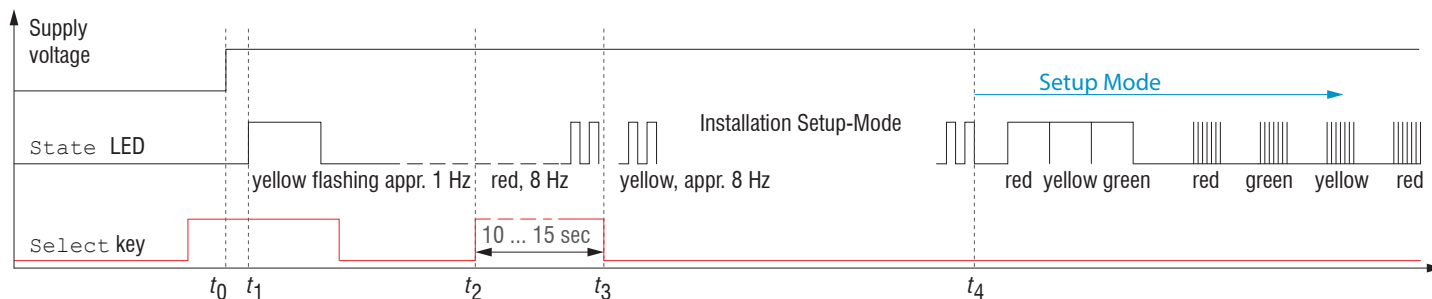

Fig. 15 Flowchart for starting a sensor in Setup-Mode

After completion of the firmware installation/switch, the sensor reboots at time t_4 .

t_0 : Supply voltage is applied

t_1 : The State LED starts flashing yellow, the Select button can be released

t_2 : Within 15 sec. ($t_2 - t_1$) press Select button again and hold for further 10 ... 15 sec. ($t_3 - t_2$)

$t_3 \dots t_4$: Switches from IO-Link to setup mode, duration max. 1 min.

t_4 : Sensor starts in the Setup mode, the State LED is flashing in the colors red, green and yellow

• A return to IO-Link operation is only possible by updating the firmware.



MICRO-EPSILON MESSTECHNIK GmbH & Co. KG
Koenigbacher Str. 15 · 94496 Ortenburg / Germany
Tel. +49 (0) 8542 / 168-0 · Fax +49 (0) 8542 / 168-90
info@micro-epsilon.com · www.micro-epsilon.com

Your local contact: www.micro-epsilon.com/contact/worldwide/

X9751491-A032036PBS

© MICRO-EPSILON MESSTECHNIK